

Investigation and Simulation of High Speed Gigabit Transmission for POF Based MOST Networks



Andreas Hohn
Alpine Electronics R&D Europe Research

Prof. Dr. Speidel / Yixuan Wang
University of Stuttgart

I.

Next Generation Infotainment Use Cases as Driver for High Speed Gigabit Transmission

II.

Investigation and Simulation of Gigabit POF Based MOST Networks

Agenda() – Overview

1 Introduction

1 External Connectivity

Next Generation Wireless standards

2 HD Video and Audio

HD Video content / Multi-seat playback

3D content

3 Connected Drive Assist – Top view camera / RVC etc.

4 Summary

Introduction

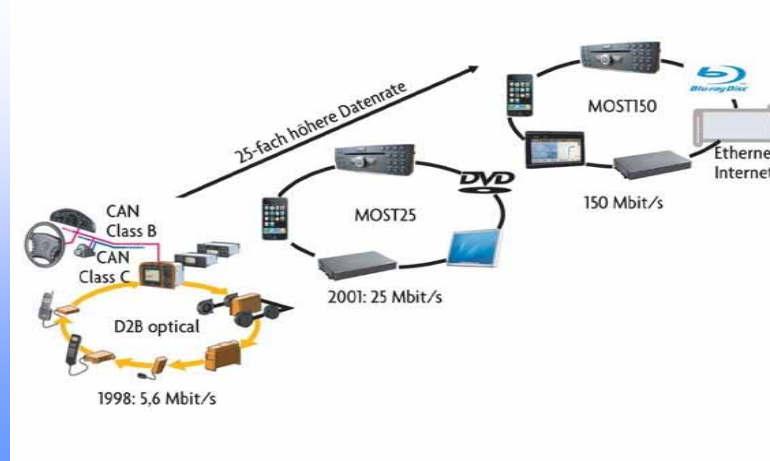

**Most 150 was specified in Oct 2007
will be on the road from 2012 for
following functions:**

- Entertainment
- Infotainment
- Mobile Connectivity
- Connected Services

...but was limited to bitrates of 150 Mbit/s



**For future generations of the MOST
network higher bandwidth with several
Gbit/s will be required for...**

- Upcoming networking standards
- HD AV streaming and 3D HDTV
- High bandwidth for mobile data transfer
- Connected Services & Apps
- Connected Drive Assist

1) External Connectivity

Summary

- 1 Integration of mobiles will require higher bandwidth for next Generation BT, WiFi, USB and HSPA
- 2 (LTE)
- 3 USB 3.0 offers speeds up to 5 Gbit/s, WiGig as up to 7 Gbit/s

Upcoming technologies like 3D or ultra-high screen resolution will cause higher bandwidth demand

Bitrate development of wireless / wired connectivity standards

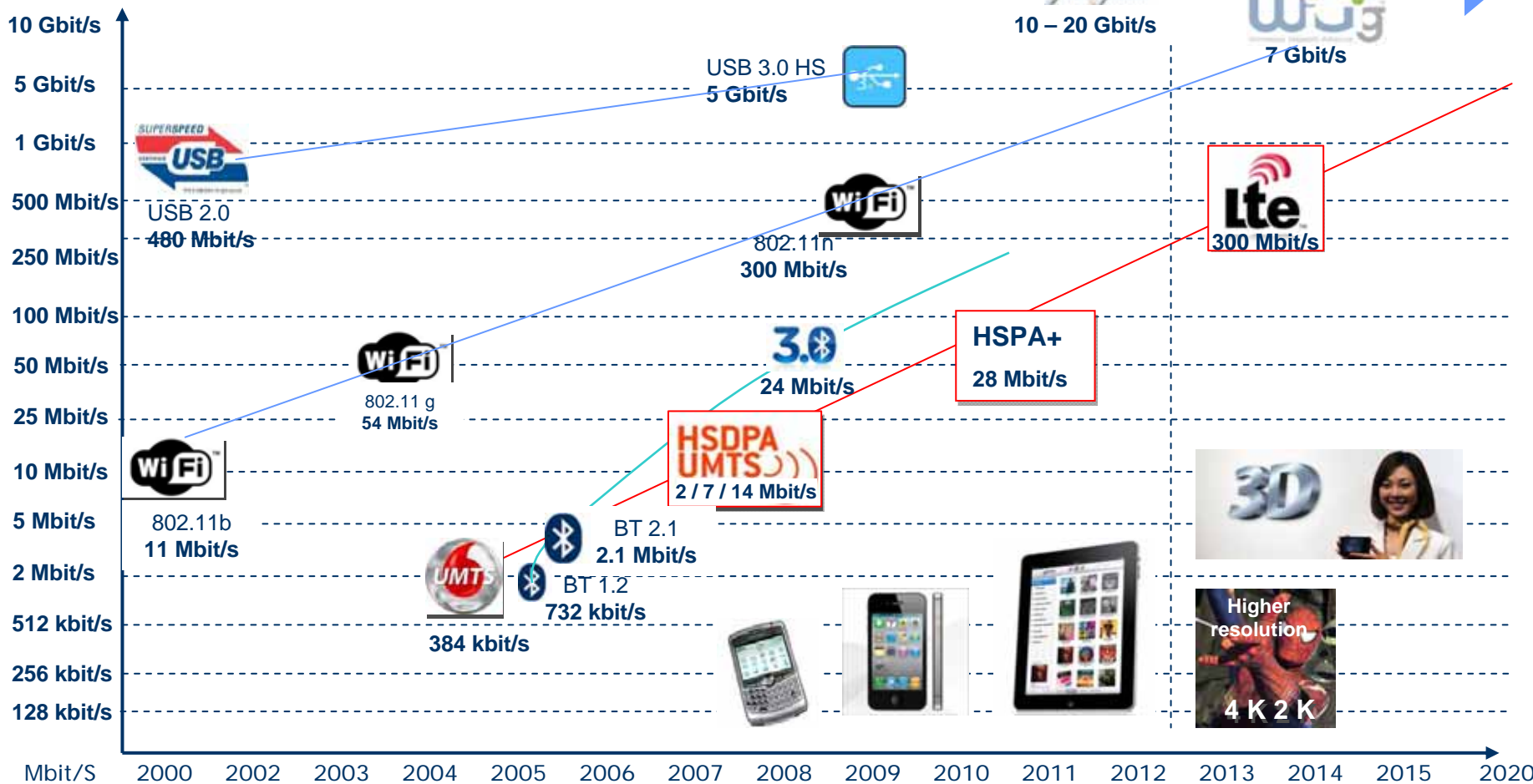

2) High Definition Video and Audio requires higher bandwidth

Summary

- 1 AV demand for HD video already is an option for premium cars and will drop to volume class
- 2 Integration of mobile devices (smartphones, tablets) as major trend (HDMI Interface)
- 3 HD displays/ 3D displays will enter the in-car infotainment → higher bandwidth needed

Next generation AV will demand higher bitrates → at least 2 Gbit/s from 2015 onwards required

Automotive AV development:
HDTV & 3D for every passenger as next hot topic



| *Today's automotive bitrates (high quality compression) | |
|---|------------------------------|
| ☐ Digital audio broadcasting (DAB) | 256 kbit/s |
| ☐ DVD-Audio (MPEG-1): | ca. 450 kbit/s to 1.4 Mbit/s |
| ☐ SD-TV (DVB-T) | ca. 3.5 Mbit/s (peak rate) |
| ☐ DVD-Video (MPEG-2): | ca. 6 Mbit/s to 9.8 Mbit/s |

| *Tomorrow's automotive requirements (2015–2020) | |
|---|---|
| ☐ HD Audio Streaming | max. 25 Mbit/s |
| ☐ Terminal Mode (HD video transfer) | ca. 30 – 50 Mbit/s (peak rate) |
| ☐ BD HD-Video (1920 x 1080p): | ca. 20 – 40 Mbit/s (peak rate) |
| ☐ BD 3D HD-Video (1920 x 1080p): | ca. 40 – 60 Mbit/s (peak rate) |
| ☐ WiFi 802.11 n (car hotspot) | ca. 150 – 300 Mbit/s (peak rate) |
| ☐ HPSA+ / LTE | ca. 28 Mbit/s / 100 to 300 Mbit/s (peak rate) |

*Wikipedia / AOEUR Research

3) Connected Drive Assist

Summary

- 1 Drive assist application will spread and become a standard in premium cars
- 2 Next Generation drive assist will require higher bandwidth to decrease latency through less
- 3 compression

Information based drive assist functions could be realized with MOST connection

Today's Drive Assist Connection

- ❑ Image data via analogue connection (NTSC) requires approx. (max. 3 Mbit/s)



Tomorrows Drive Assist Connection

- ❑ Digital Connection via MOST up to 2 -3 GB
- ❑ Digital Connection via Ethernet 100 Mbit/s
- ❑ Display Connection via LVDS / APIX2 up to 3.2 Gbit/s

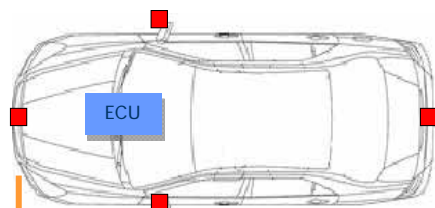

2009

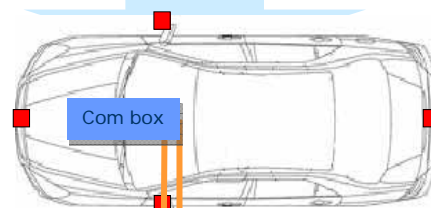

2020

2013

2015

Lane assist / keeping



Blind spot



Rear object detection



Augmented reality



Car 2X / Car 2 Car



Traffic sign recognition



Top view



Cross traffic assist



Side mirror camera



Other functionalities



Night Vision



4) Summary

Summary

- ❑ **Demand of higher bandwidth for next generation infotainment exists**

- ❑ **Drivers for higher speed transmission are:**
 - **HD Audio/Video & 3D Video**
 - **Multi-Seat infotainment**
 - **Next Generation wireless networks (e.g. UMTS towards → LTE)**
 - **Integration of mobile devices (smartphone, tablets)**
 - **Drive assist applications will become more common, even on volume cars**

Overview

1 Target and emphasis

2 System approaches

Modeling of the optical channel

SNR estimation

Scheme A-1: merely post adaptive equalizers

Scheme A-2: Pre-filtering with post adaptive equalizers

Scheme B: Tomlinson-Harashima precoding with zero forcing equalizers(THP-ZF)

3 Simulation results

4 Summary

Overview

1**Target and emphasis****2****System approaches**

Modeling of the optical channel

SNR estimation

Scheme A-1: merely post adaptive equalizers

Scheme A-2: Pre-filtering with post adaptive equalizers

Scheme B: Tomlinson-Harashima precoding with zero forcing equalizers(THP-ZF)

3**Simulation results****4****Summary**

Target and emphasis

- 2-3Gbit/s data transmission over POF based physical layer
- Cost efficient LED and PD from MOST150 physical platform
- Cost efficient LED instead of LD

Overview

1 Target and emphasis

2 **System approaches**

Modeling of the optical channel

SNR estimation

Scheme A-1: merely post adaptive equalizers

Scheme A-2: Pre-filtering with post adaptive equalizers

Scheme B: Tomlinson-Harashima precoding with zero forcing equalizers (THP-ZF)

3 Simulation results

4 Summary

Modeling of the optical channel



| | | |
|---|--|---------|
| 3dB Bandwidth depending on LPOF | 10m POF | 135 MHz |
| | 15m POF | 95 MHz |
| Transfer function of the overall optical link | $H_o = A \cdot e^{-2(\pi\sigma f)^2} \cdot e^{-j \cdot 2\pi f \tau \cdot L_{pof}}$ | |

*) Valid for 1mm polymer optical step index fiber with launch condition NA 0.5

SNR estimations

- The main source of noise in the receiver are the shot noise(quantum noise and the diode dark current noise) and the thermal noise

- SNR

$$\begin{aligned}
 SNR &= \frac{\langle I_p^2 \rangle}{\langle I_{shot}^2 \rangle + \langle I_{thermal}^2 \rangle} \\
 &= \frac{(R_0 \cdot P)^2}{2 \cdot e \cdot (R_0 \cdot P + I_{dark}) \cdot B + \frac{4 \cdot k \cdot T \cdot B}{R}}
 \end{aligned}$$

SNR estimations

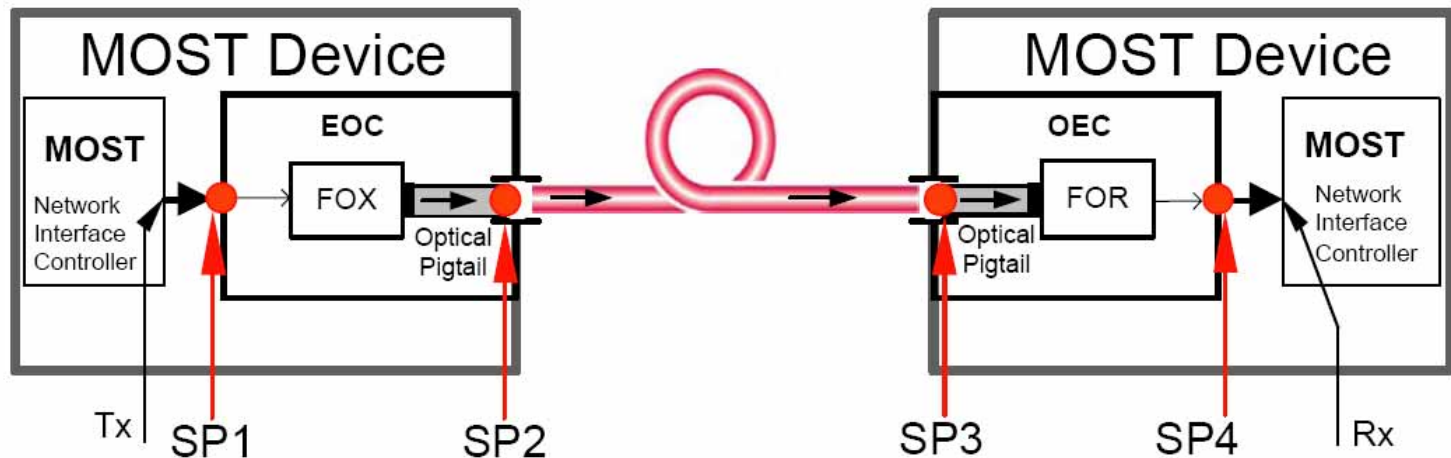
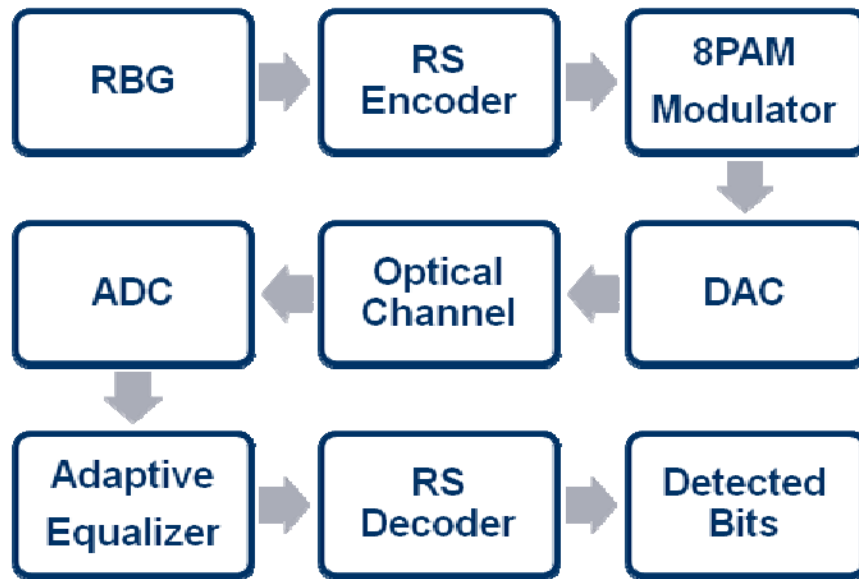

Figure 4-3: Location of Specification Points

- The received optical power at SP3: -22dBm ~ -2dBm
- With $R = 50\Omega$ and T at 300K, the estimated SNR ranges from 20.4dB ~ 59.5dB without a pre-filter (BW=135MHz) and from 18.4dB ~ 57.6dB with a pre-filter (BW=210MHz)

Scheme A-1: Merely adaptive post equalization



To cope with ISI (inter-symbol-interference)

- RS (255,223) coding
- 8PAM reduces the symbol rate by factor 3
- FFE or DFE Post adaptive equalizers are used to follow the optical channel changes

Scheme A-2: Pre-filtering and adaptive post equalization

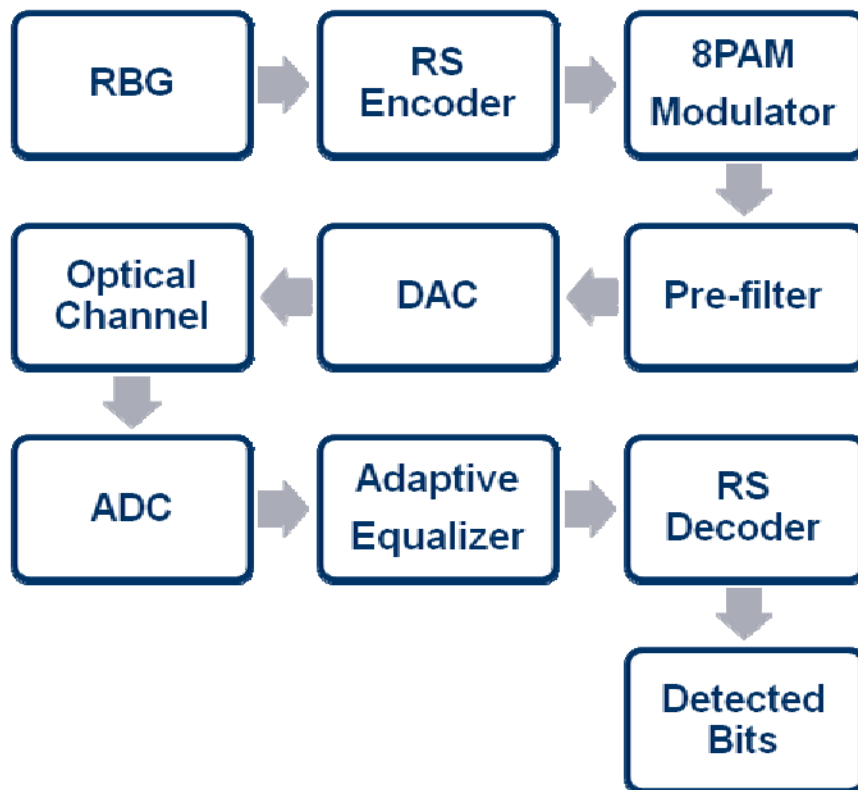

To cope with ISI

- RS (255,223) coding
- 8PAM reduces the symbol rate by factor 3
- FFE or DFE Post adaptive equalizers are used to follow the optical channel changes
- For 3Gbit/s transmission, a high-pass filter is inserted as a pre-filter

Scheme A: Pre-filtering and adaptive post equalization

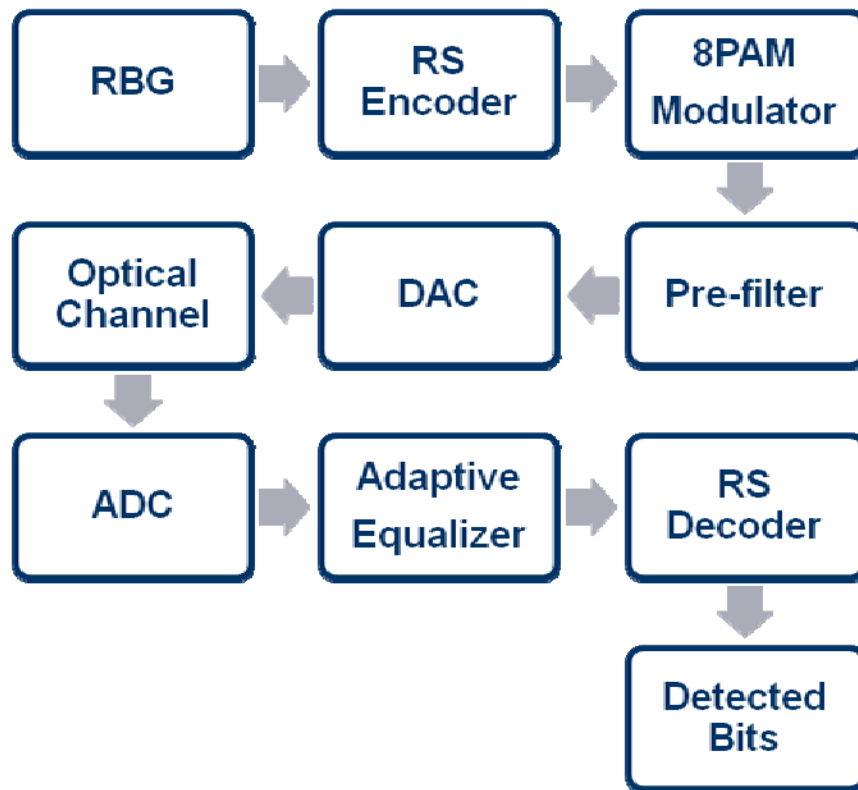

Scheme B: Tomlinson-Harashima precoding and post equalization(ZF-THP)

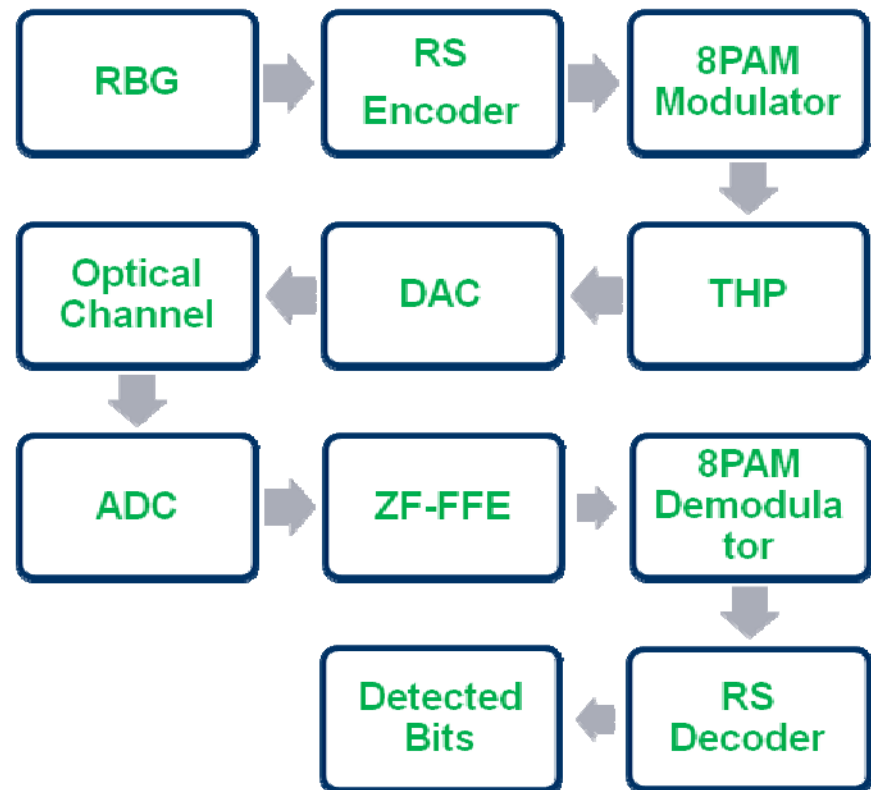

Overview

1 Target and emphasis

2 System approaches

Modeling of the optical channel

SNR estimation

Scheme A-1: merely post adaptive equalizers

Scheme A-2: Pre-filtering with post adaptive equalizers

Scheme B: Tomlinson-Harashima precoding with zero forcing equalizers(THP-ZF)

3 **Simulation results**

4 Summary

Scheme A-1:
Post fractionally spaced equalizers (K=2) and RS coding; No pre-filter, no precoding:

▪ **Parameters:**

- 8PAM
- $R_b = 2$ and 3Gbit/s
- POF length = 10m
- FFE and DFE with RLS and LMS algorithms

▪ **Target:**

BER smaller than $5 \cdot 10^{-3}$, so RS(255,223) coding can further decrease the BER to 10^{-9} .

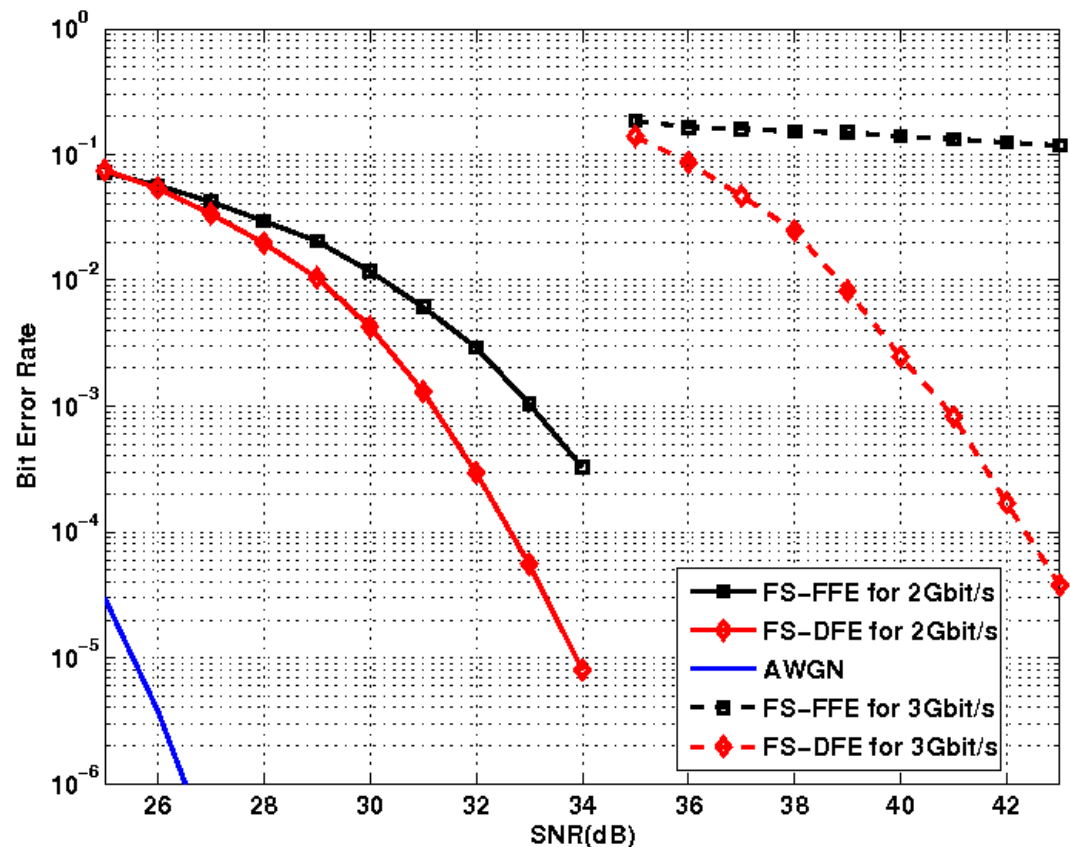

Scheme A-1:
Post fractionally spaced equalizers ($K=2$) and RS coding; No pre-filter, no precoding:

▪ **Results:**

- SNR range: 20.4dB ~ 59.5dB
- Target is reached when SNR=31.5dB for DFE and 33.5dB for FFE at 2Gbit/s
- Target is reached when SNR=41.5dB for DFE at 3Gbit/s, which is a middle SNR value

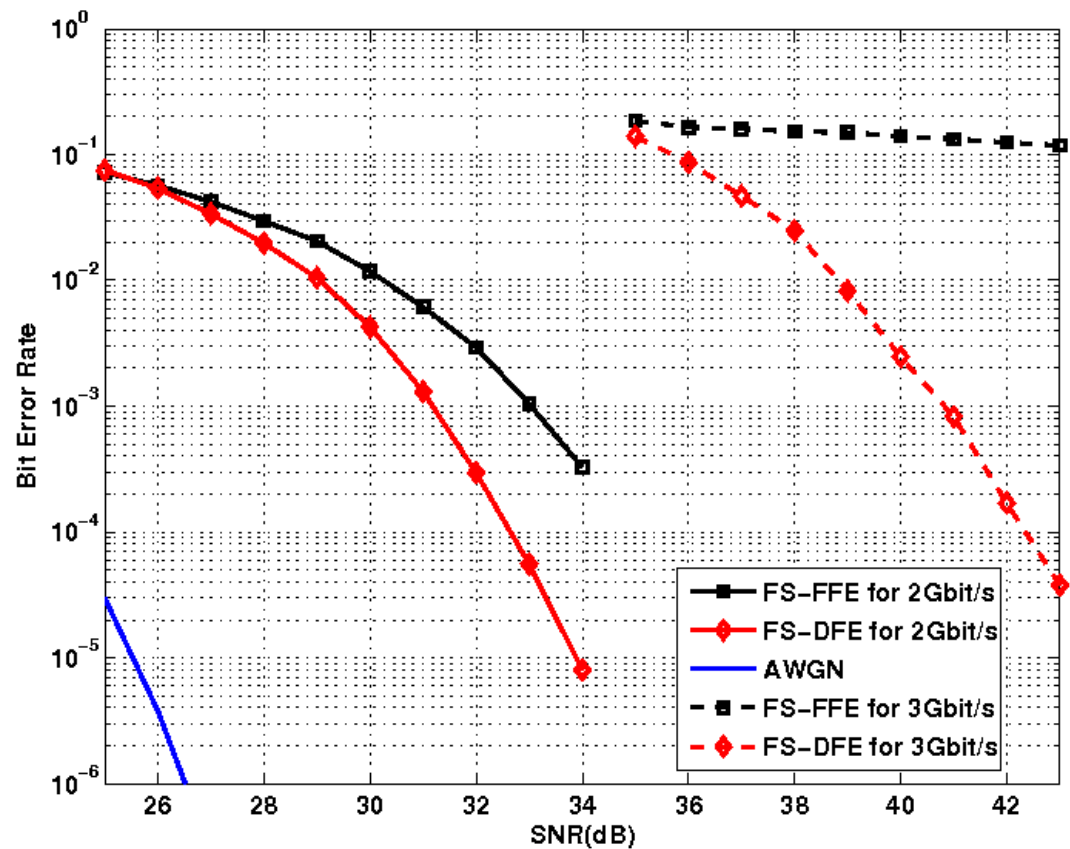

Agenda(III) – Simulation results – Scheme A-2: Pre-filter and post equalization

Scheme A-2: Pre-filter, post fractionally spaced equalizers ($k=2$) and RS coding:

- Pre-filter causes negative values in the transmit signal, a DC must be added so they can be launched into the LED
- The actual transmit signal power is reduced due to the power spent on DC
- Thus, the SNR upper limit without DC power decreases to 32dB.

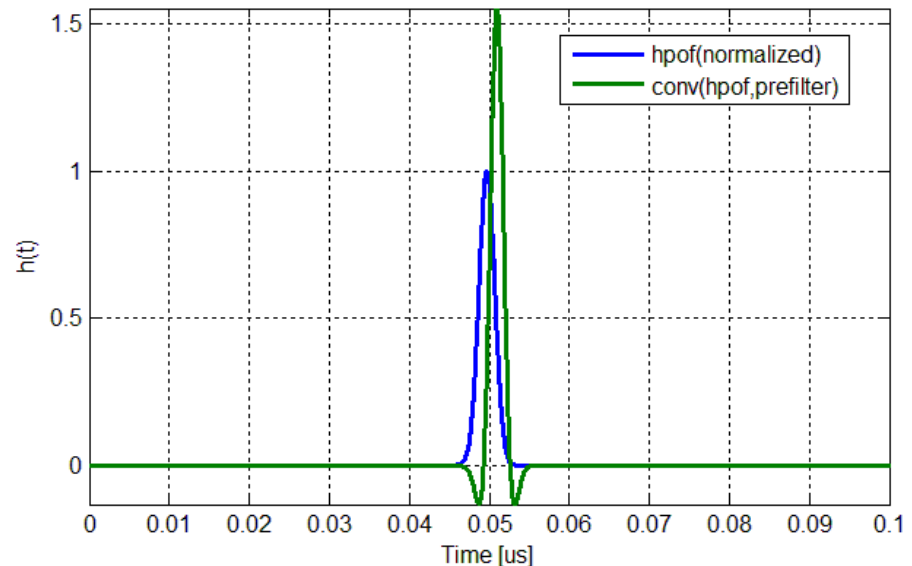
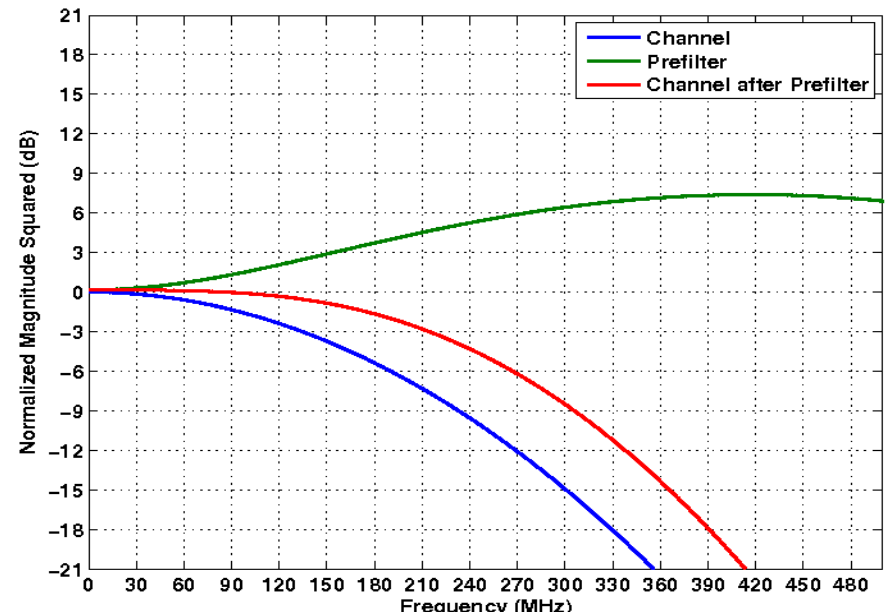

Scheme A-2: Pre-filter, post fractionally spaced equalizers ($k=2$) and RS coding:

Parameters:

- 8PAM
- $R_b = 3\text{Gbit/s}$
- POF length = 10m
- **FS-pre-filter (order 5)**
- FS-FFE and FS-DFE with RLS and LMS algorithms;

Target:

BER smaller than $5 \cdot 10^{-3}$, so RS(255,223) coding can further decrease the BER to 10^{-9} .

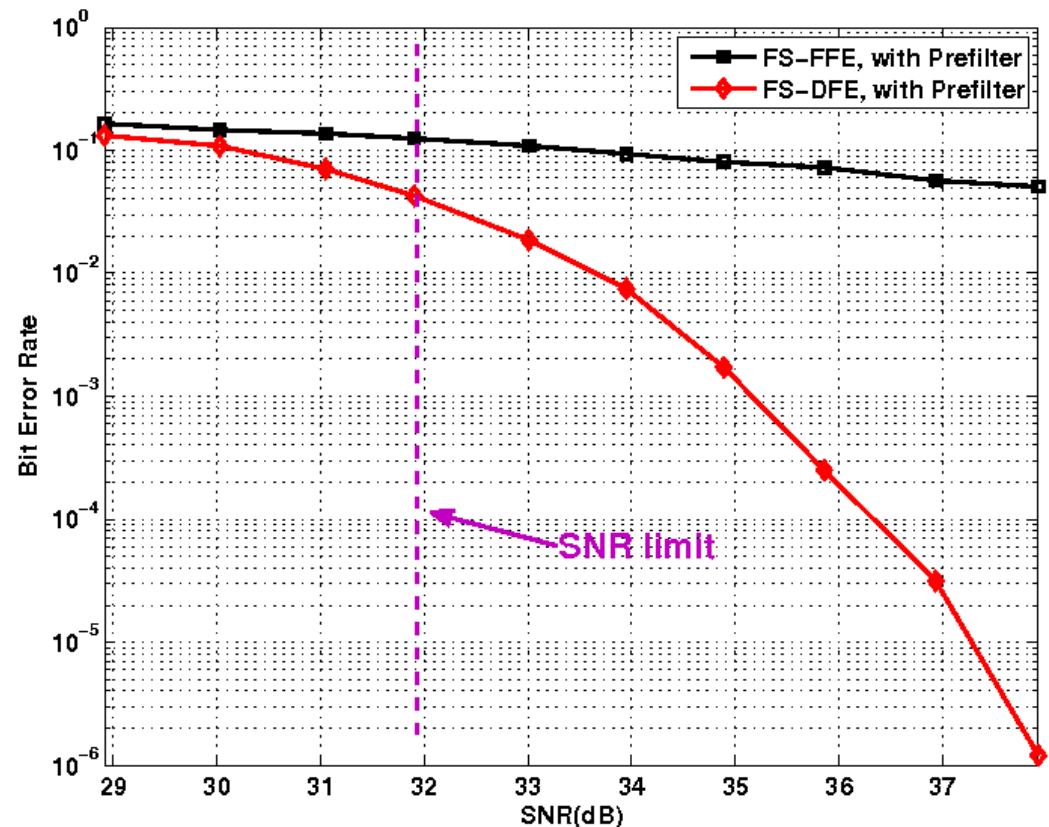

Scheme A-2: Pre-filter, post fractionally spaced equalizers (k=2) and RS coding:

▪ Results:

- BER curves decrease faster than without pre-filter
- SNR upper limit: 32dB
- But target is reached at SNR = 35.5dB
- An extra 3-4dB is needed to make the transmission possible

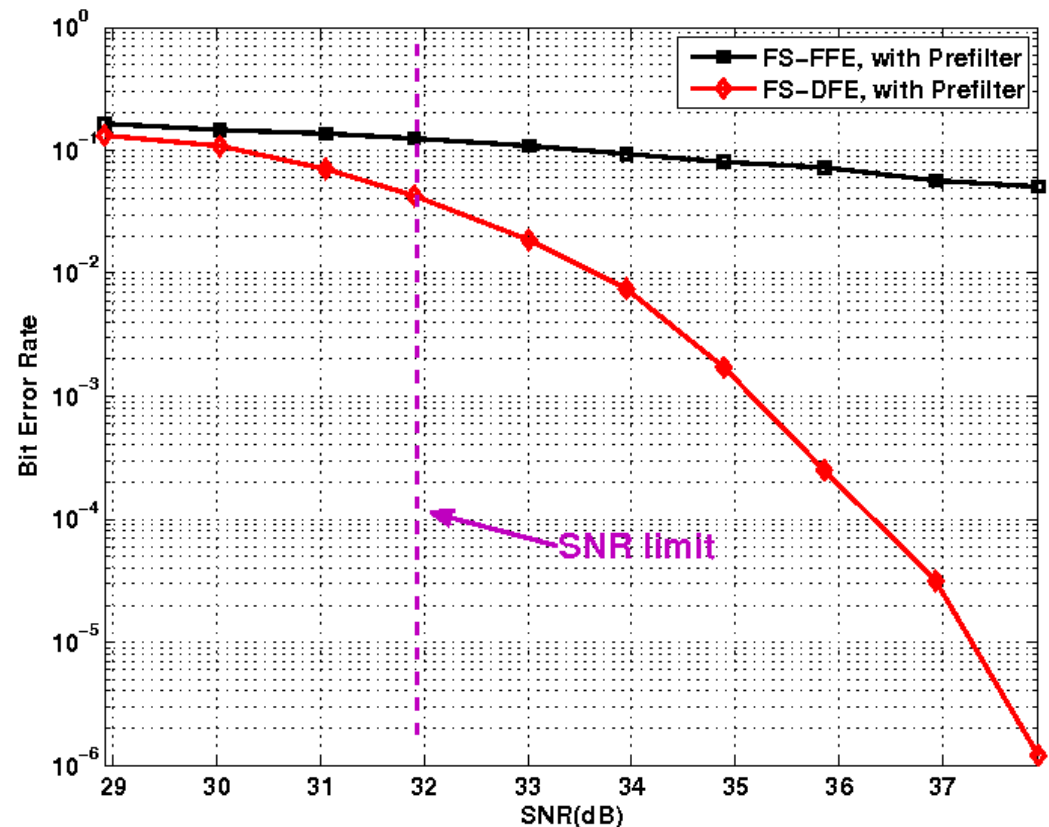

Scheme B: Tomlinson-Harashima precoding and post zero forcing equalization

- THP avoids noise enhancement and error propagation
- THP bounded the dynamic range of the transmit signal
- THP increases the dynamic range of the received signal and brings extra losses to the SNR
- The decrease in SNR is related to the bit rate

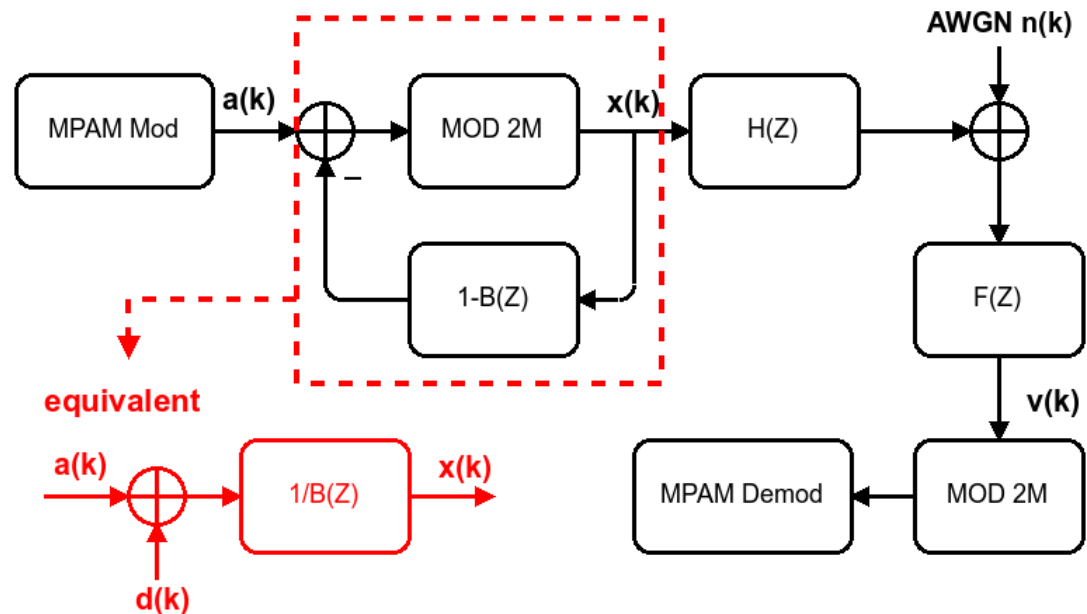

Scheme B: Tomlinson-Harashima precoding and post zero forcing equalization

Parameters:

- 8PAM
- $R_b = 2\text{Gbit/s}$
- POF length = 10m
- Zero Forcing Post Equalizers with 19-25 taps;

Target:

BER smaller than $5 \cdot 10^{-3}$, so RS(255,223) coding can further decrease the BER to 10^{-9} .

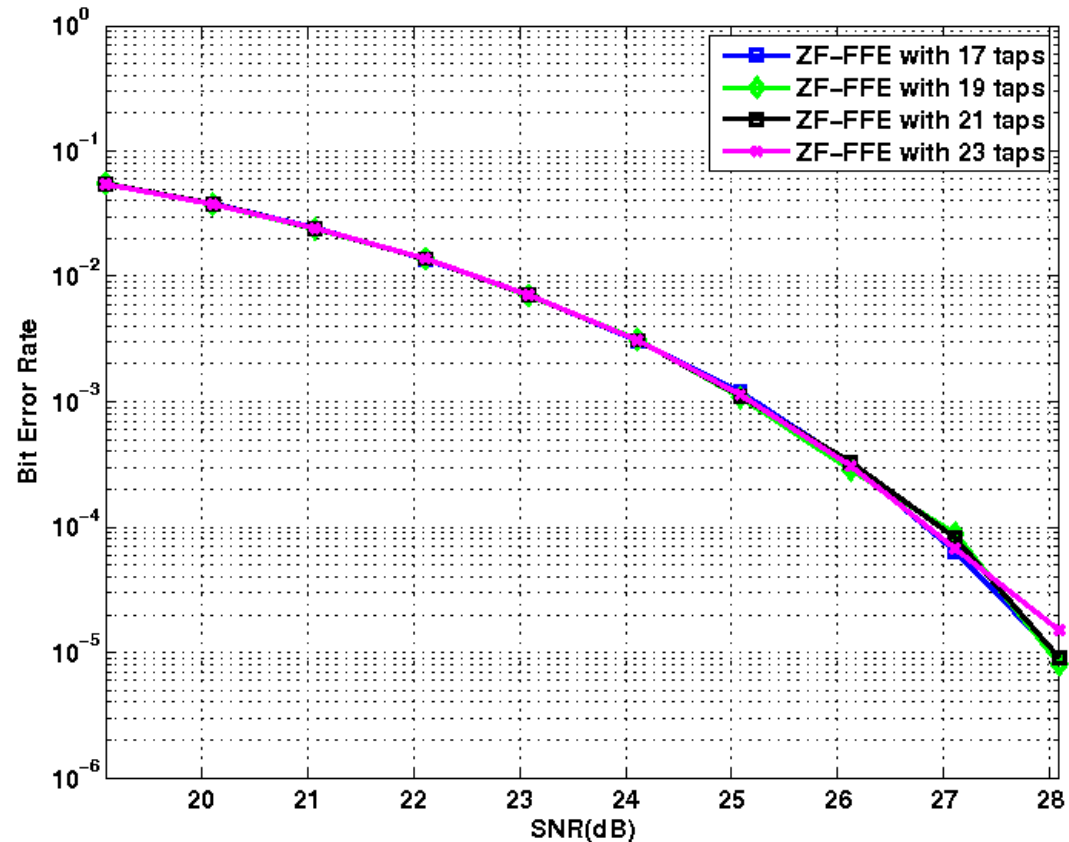

Scheme B: Tomlinson-Harashima precoding and post zero forcing equalization

- **Results:**
- SNR range: 11.5dB ~ 50.6dB.
- Target is reached at 25.5dB, which is in the lower SNR range
- BER curves decrease less shaper as post equalization.

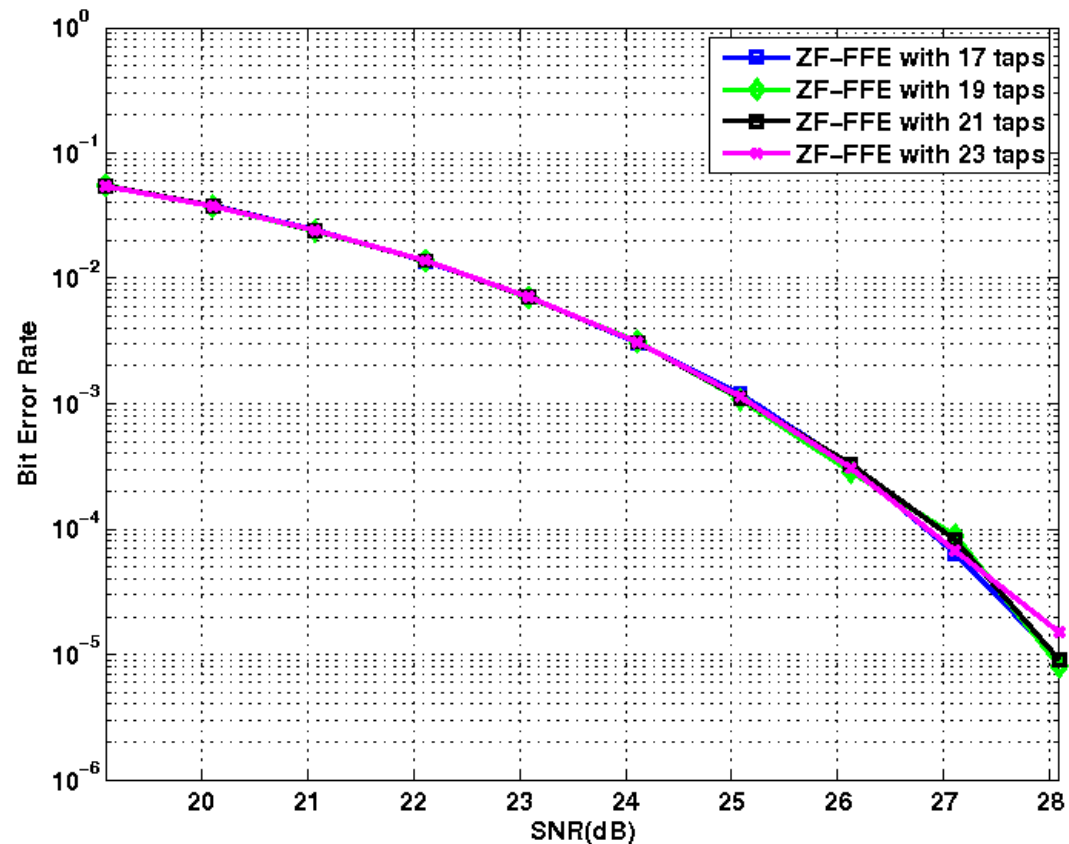

Scheme B: Tomlinson-Harashima precoding and post zero forcing equalization

Parameters:

- 8PAM
- $R_b = 3\text{Gbit/s}$
- POF length = 10m
- Zero Forcing Post Equalizers with 19-25 taps;

Target:

BER smaller than $5 \cdot 10^{-3}$, so RS(255,223) coding can further decrease the BER to 10^{-9} .

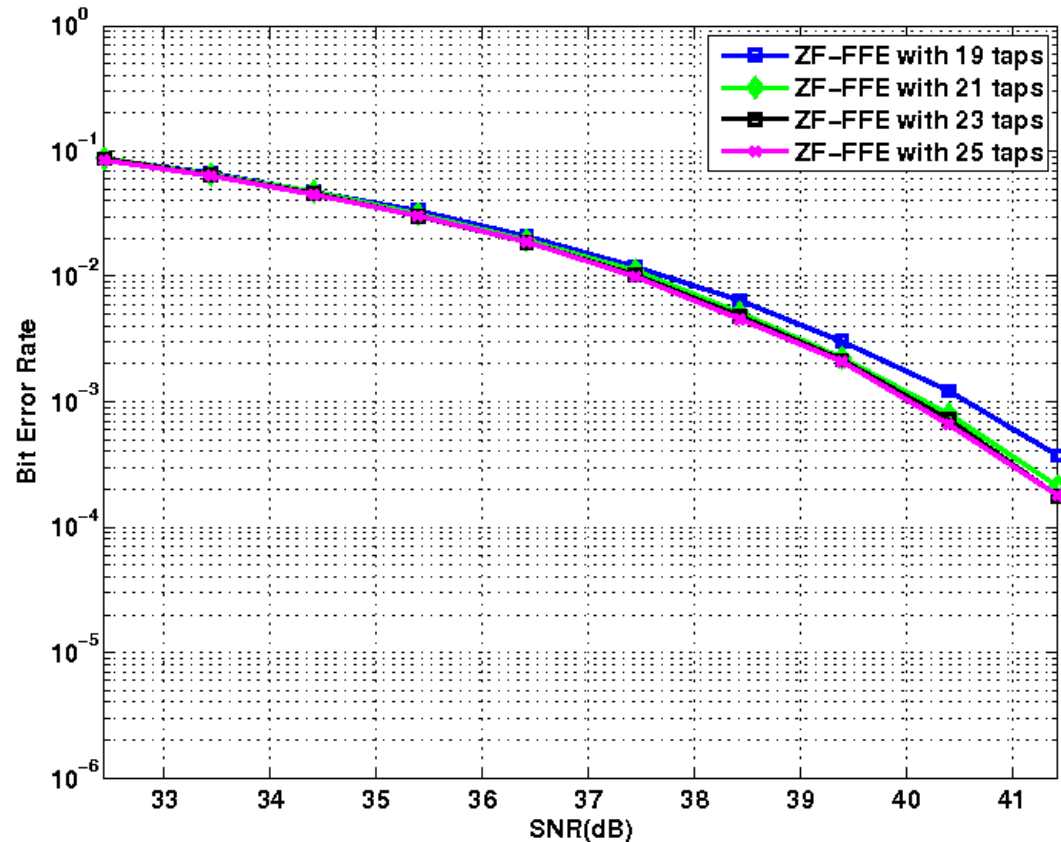

Scheme B: Tomlinson-Harashima precoding and post zero forcing equalization

Results:

- SNR range: 10dB ~ 49dB
- Target is reached at 40.5dB, which has 10dB margin to the SNR upper limit.
- Comparing with post DFE scheme, which has an 18dB margin, ZF-THP performs worse

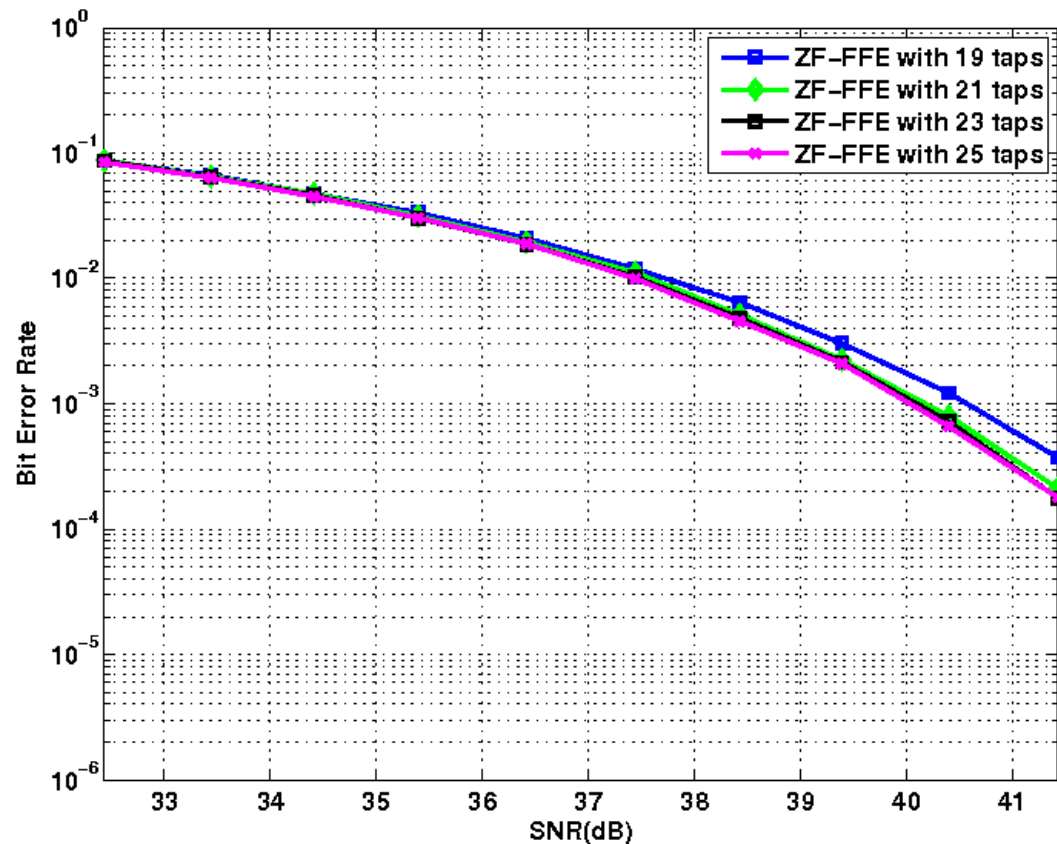

Overview

1 Target and emphasis

2 System approaches

Modeling of the optical channel

SNR estimation

Scheme A-1: merely post adaptive equalizers

Scheme A-2: Pre-filtering with post adaptive equalizers

Scheme B: Tomlinson-Harashima precoding with zero forcing equalizers(THP-ZF)

3 Simulation results

4 **Summary**

Summary

- Scheme A-1: merely post equalization
FFE has a 2.5Gbit/s data rate limit. For DFE scheme, 3Gbit/s transmission is achieved by middle value optical transmit power
- Scheme A-2, pre-filter and post equalization
The 3Gbit/s transmission is only possible if the SNR upper limit is 3-4dB higher
- Scheme B: ZF-THP
It is feasible at both 2 and 3Gbit/s, but higher SNRs are required compared with the post DFE scheme