



**Payload efficiency and network considerations of MOST
and Ethernet**

**Helge Zinner, Josef Nöbauer
Continental Automotive GmbH**

Motivation Ethernet – THE MOST POPULAR NETWORK

Ethernet im Automobil

Mehr als nur reine Diagnose!

Micrel, 01/2011

Datenübertragung im Auto

Ethernet eignet sich für Infotainment im Auto

Elektronik Praxis, Forschung Fraunhofer ,03/2011

BMW, Broadcom Leading Auto
Industry into Ethernet Era

Strategyanalytics, 06/2010



MOST Cooperation Presents the Physical
Layer for Ethernet in the Car

www.mostcooperation.com, 2008

SEIS Project,

<http://www.strategiekreis-elektromobilitaet.de>

Dafür sind Erweiterungen des Ethernet- Standards wie Ethernet-“Audio Video Bridging“ (AVB) zwingend erforderlich. Eine Konkurrenz zu MOST könnte entstehen, wenn oben genannte Ethernet- Technologien in der Breite verfügbar wären und dementsprechend günstig würden. Die Entscheidung für die eine oder andere Technologie dürfte neben den Kosten auch von der Systemarchitektur und der Verkabelungsstrategie der Automobilhersteller abhängen.

Für die, die heute bereits MOST im Einsatz haben, mag ein kompletter Umstieg auf Ethernet schwierig sein, jedoch wäre gerade auch eine Kombination beider Technologien durchaus sinnvoll.

J. K. Wagenbrenner,

Harman International Automotive Division, 06/2010

Motivation

▶ Future challenges for multimedia data transport

- Higher total bandwidth (Blu-Ray, Integration of IP-based devices)
- Interworking of ADAS and Infotainment network
- Fast data transport for real time video (e.g. bird view)

▶ MOST and Ethernet AVB

- Different technologies (layering, flexibility, speed, application area, ...)
- Both designed for high quality multimedia transport
- Shared bandwidth vs. dedicated links

Bandwidth Requirements

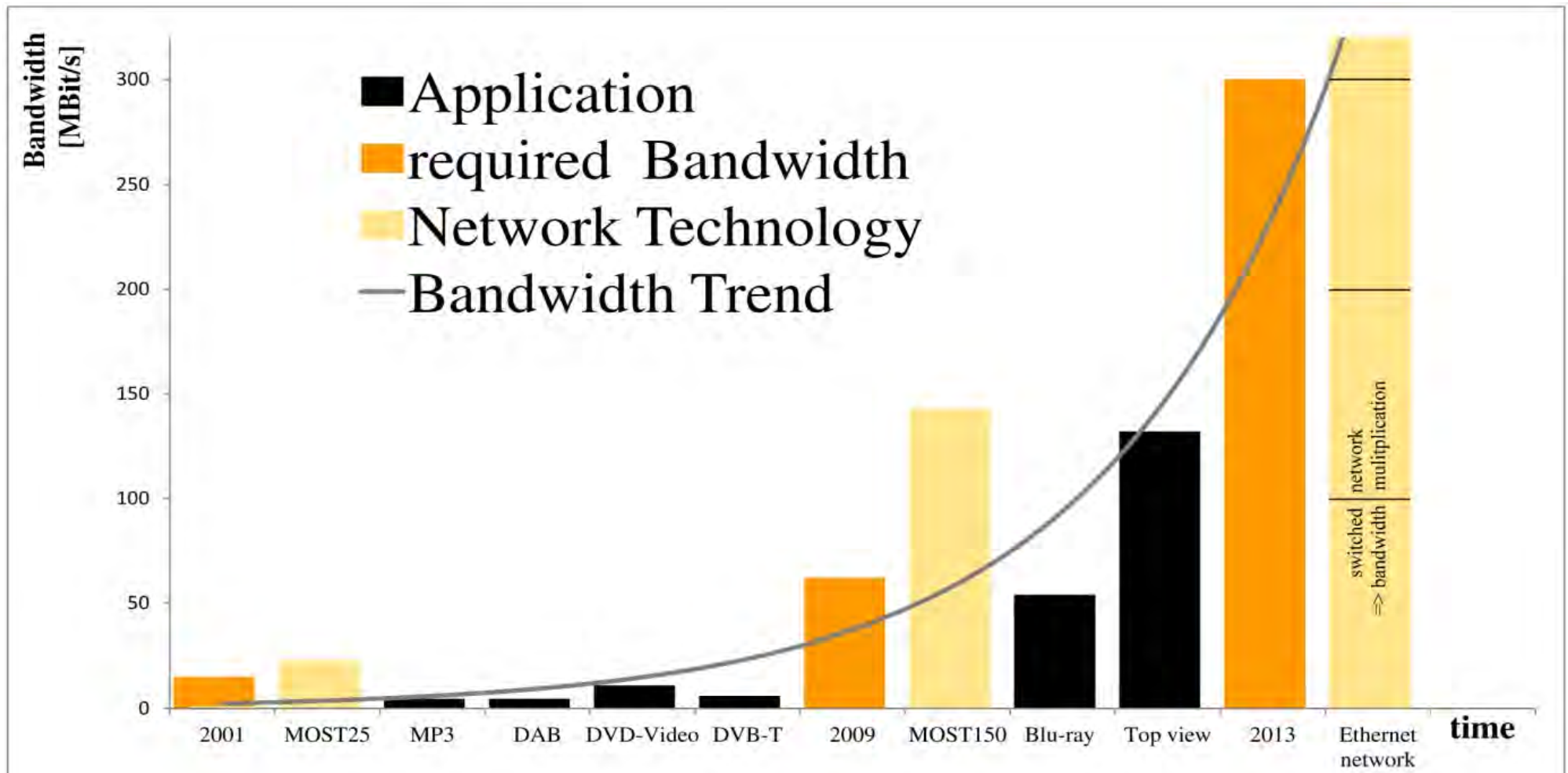

▶ This requires a detailed view to see the efficiency of the data transport

Introduction Ethernet AVB

- ▶ 802.1AS Time synchronization
- ▶ 802.1Qav Forwarding and Queuing enhancements
- ▶ 802.1Qat Stream Reservation Protocol

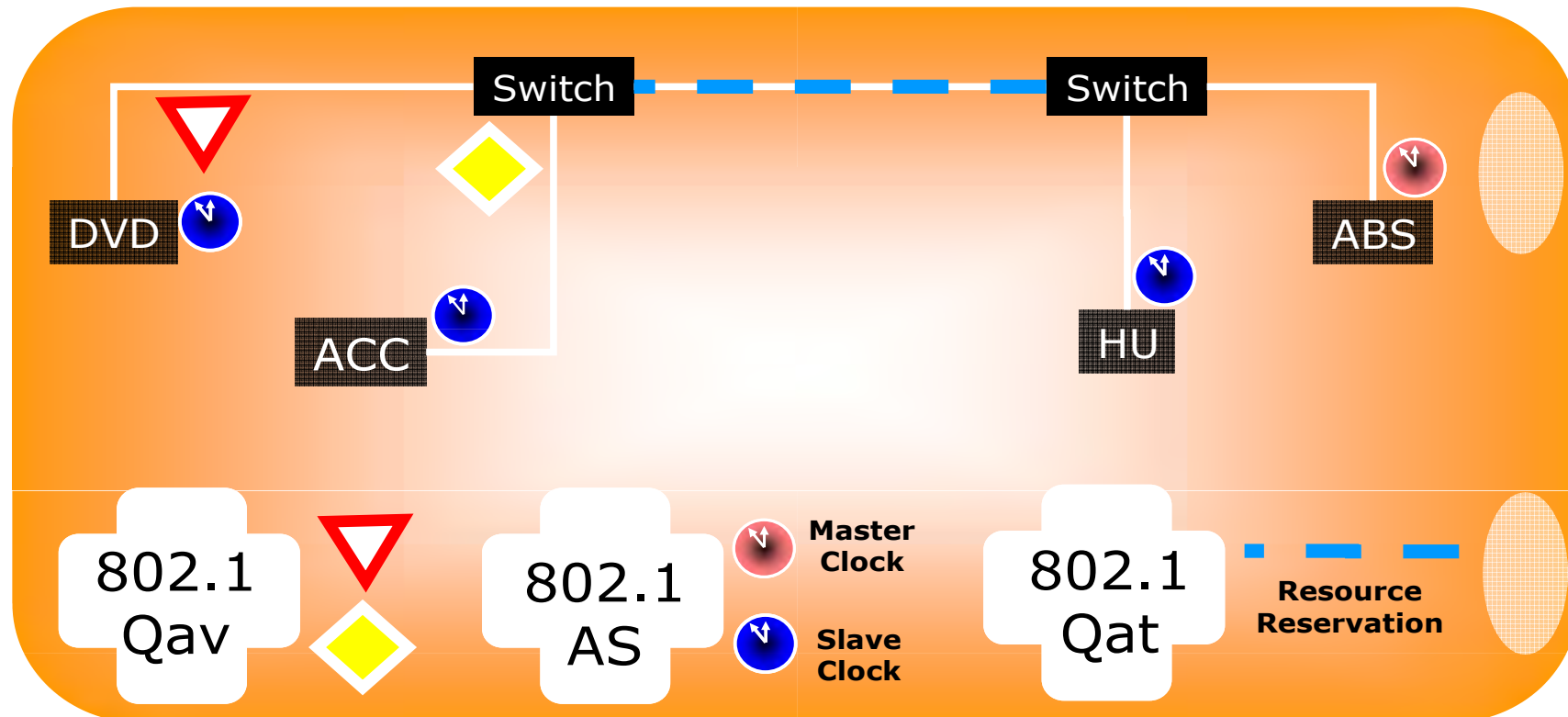

Audio transport AVB

▶ IEEE1722 Frame including IEC61883-6 audio format

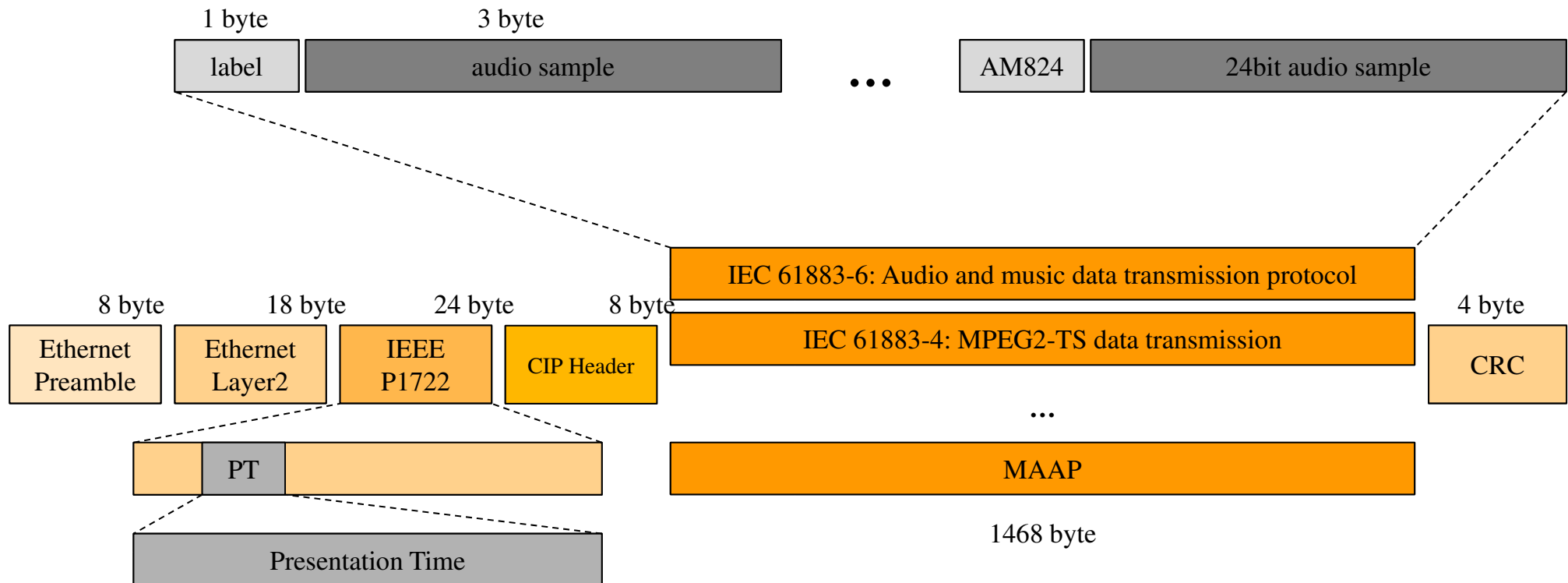

Payload Efficiency

▶ Automotive Streaming Use Cases

$$PE = \frac{\text{Payload } (P)}{\text{Sent data } (D)}$$

- MOST provides always 100% payload efficiency
- Ethernet efficiency increases with payload size
- Sending frequency of 1722 frames is inverse proportional to efficiency

Streaming Use Cases	Payload [MBit/s]		MOST150			AVB 1722 Class A			AVB 1722 Class B		
	P		Sent Data [MBit/s]	PE		Sent Data [MBit/s]	PE		Sent Data [MBit/s]	PE	
CD-A Stereo 16bit audio stream Sampling rate 44,1kHz	P_{CD-A}	1.41	$D_{MOST150_CD-A}$	1.41	100%	D_{AVB-A_CD-A}	6.8	20.8%	D_{AVB-B_CD-A}	4.8	29.3%
DVD-Audio, Dolby Digital 5.1 24bit audio stream, no DTCF Sampling rate 48kHz	P_{DVD-A}	6.91	$D_{MOST150_DVD-A}$	6.91	100%	D_{AVB-A_DVD-A}	13.2	52.4%	D_{AVB-B_DVD-A}	11.2	61.7%
Live Video (from Camera) Resolution 1280*800, 30fps MJPEG (compression factor 15)	$P_{LiveVideo}$	33	$D_{MOST150_LiveVideo}$	33	100%	$D_{AVB-A_LiveVideo}$	39.7	83.1%	$D_{AVB-B_LiveVideo}$	35.7	92.5%
Blu-ray Compr. audio and video stream with constant bit rate	$P_{Blu-ray}$	41.1	$D_{MOST150_Blu-ray}$	41.1	100%	$D_{AVB-A_Blu-ray}$	45.9	89.5%	$D_{AVB-B_Blu-ray}$	43.9	93.6%

Network utilization

- ▶ MOST bandwidth is shared for all nodes

- This causes less available bandwidth per node

$$NU = \frac{\text{Data rate } (D)}{\text{avail. bandwidth } (B)}$$

- ▶ Ethernet AVB is based on switched Ethernet, i.e. no CSMA/CD

- Full bandwidth (100MBit/s, 1GBit/s ...) available for each link
 - Full duplex mode (100 % in Table below corresponds to 100 MBit/s unidirectional)
 - NU depends on topology

Vehicle Architectures	MOST150		AVB 1722 Class A		AVB 1722 Class B	
	$B_{MOST150}$ 142,9 MBit/s	NU	B_{AVB} 98,4 MBit/s	NU	B_{AVB} 98,4 MBit/s	NU
Infotainment Domain	90.5	63.3%	111.8	37.9%	103.8	35.2%
ADAS Domain 4 Cams	132	92.4%	158.8	40.4%	142.7	36.3%
ADAS Domain 5 Cams	165	115.5%	198.6	40.4%	178.4	36.3%

Network considerations

- ▶ Overall required network bandwidth > 200 Mbit/s
- ▶ A single MOST150 network does not provide sufficient bandwidth for ADAS and Infotainment
- ▶ Switched Ethernet (@100Mbit/s full duplex) fulfills those needs

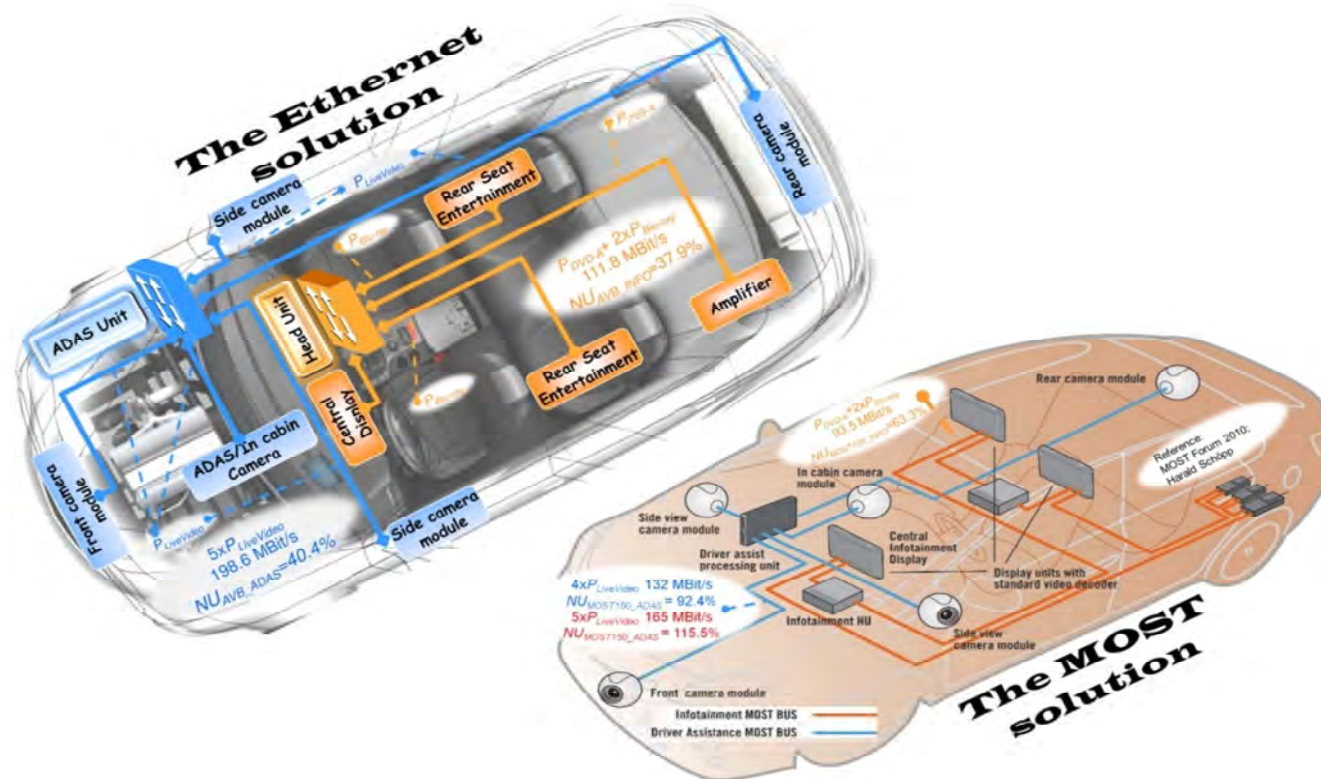

MOST/AVB Gateway

- ▶ Both technologies can work together (Demonstrator system available)
 - Fully synchronized
 - No SRC and no additional buffer required
- ▶ 802.1AS provides the basis for overall network synchronization
- ▶ Integration of IP world is enhanced

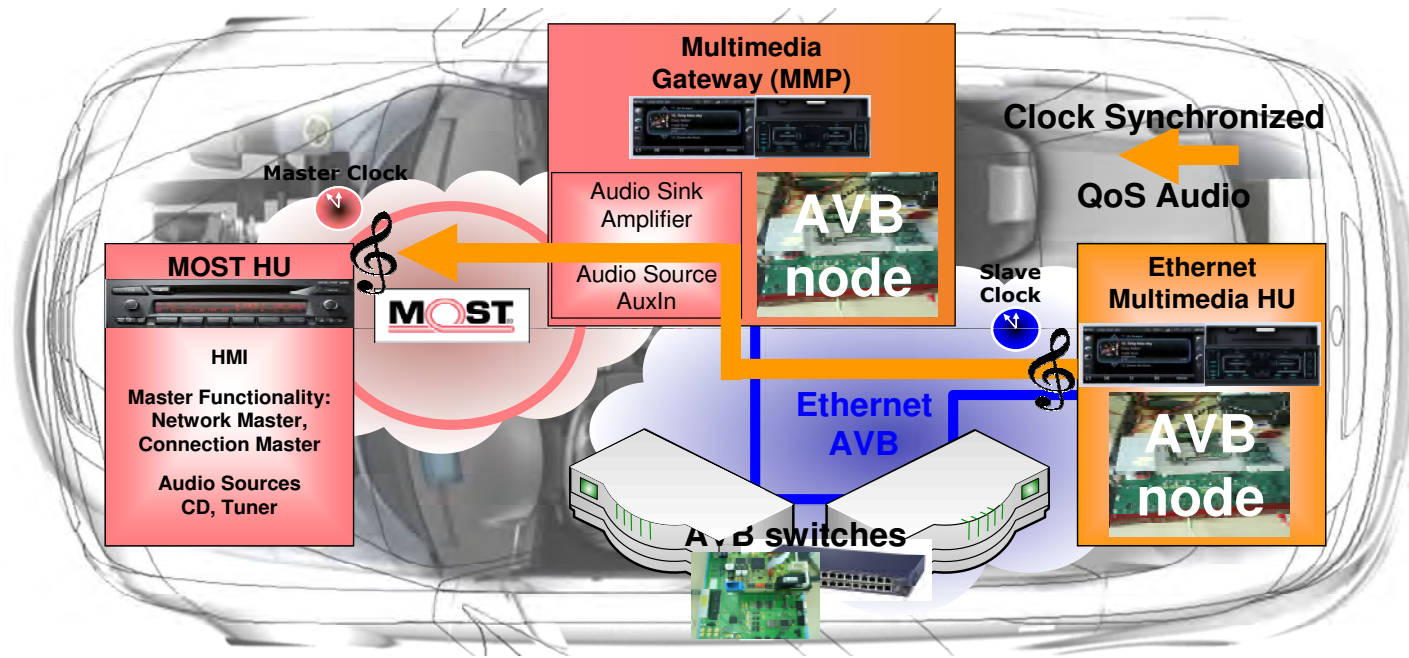

Conclusions

- ▶ Ethernet is well known for low efficiency with small frames
 - Payload Efficiency is more critical for Ethernet
 - Well configuration is important since only 75% link capacity can be used
 - AVB group integrates more MIME types, works on reducing frame overhead

- ▶ Network bandwidth is continuously increasing
 - Network utilization is at least as important as payload efficiency

- ▶ Proposed MOST/AVB Gateway fits both needs and can address multiple use cases
 - MOST = high efficient media streaming
 - Ethernet = higher total bandwidth



Arriving safely and comfortably

Thank you for your attention