

DAIMLER

Using UPnP in a MOST Environment

MOST Forum – 23-03-2010

Alexander Leonhardi, Thomas Gschwandtner,
Rico Hauke, Matthias Stümpfle

Overview

Motivation

Implementing UPnP on MOST

Introducing UPnP on MOST

Conclusion

Vehicle Domains

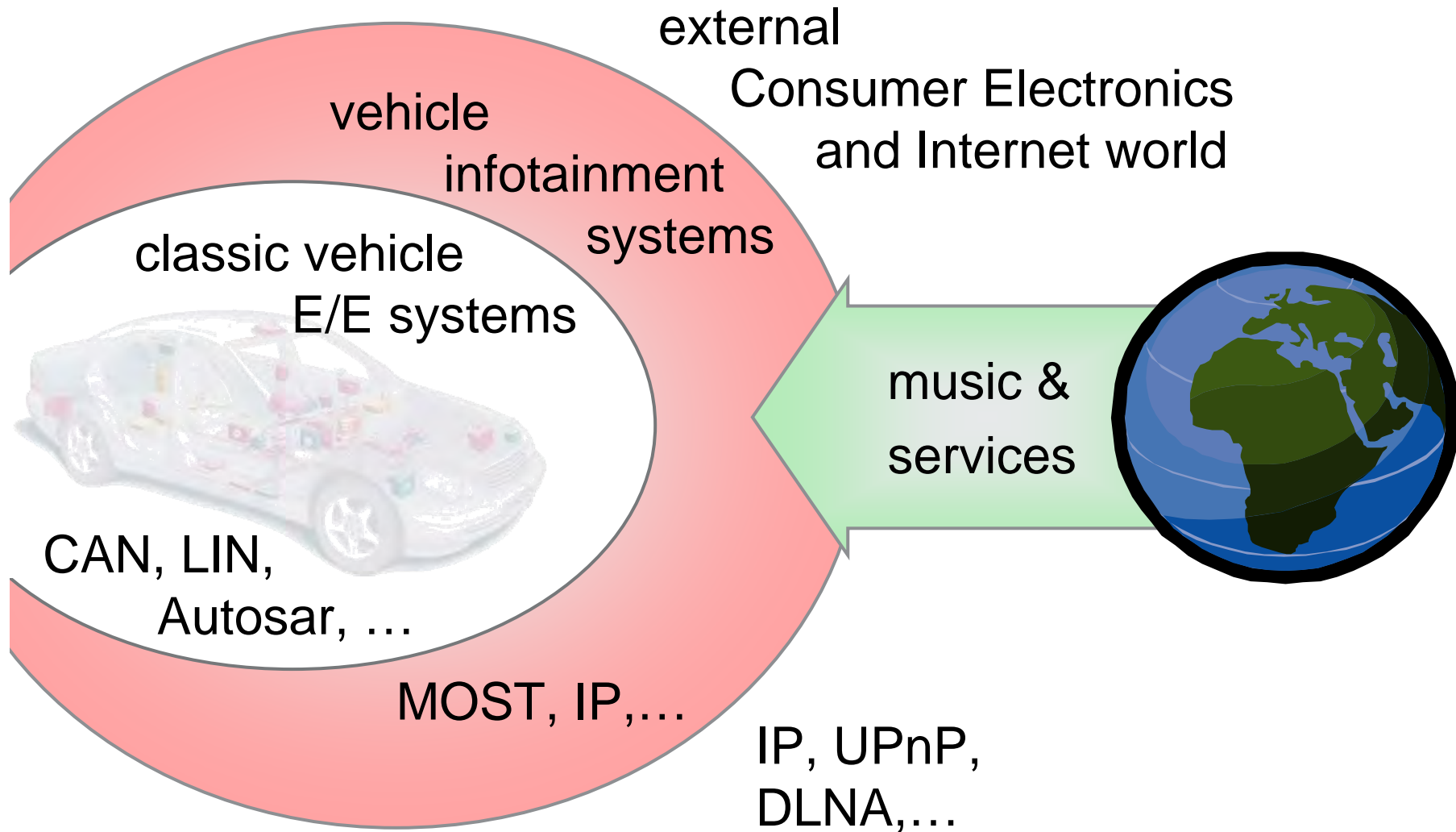

Standards



- de-facto standard for car infotainment
- reliable optical physical layer
- synchronous physical layer
- interfaces for infotainment applications
- MOST150: Ethernet channel



- connects home entertainment devices
- uses widespread standards from IT industry
- mechanisms for detecting devices in an IP network
- mechanisms for providing and using services
- DLNA ensures interoperability

UPnP over MOST

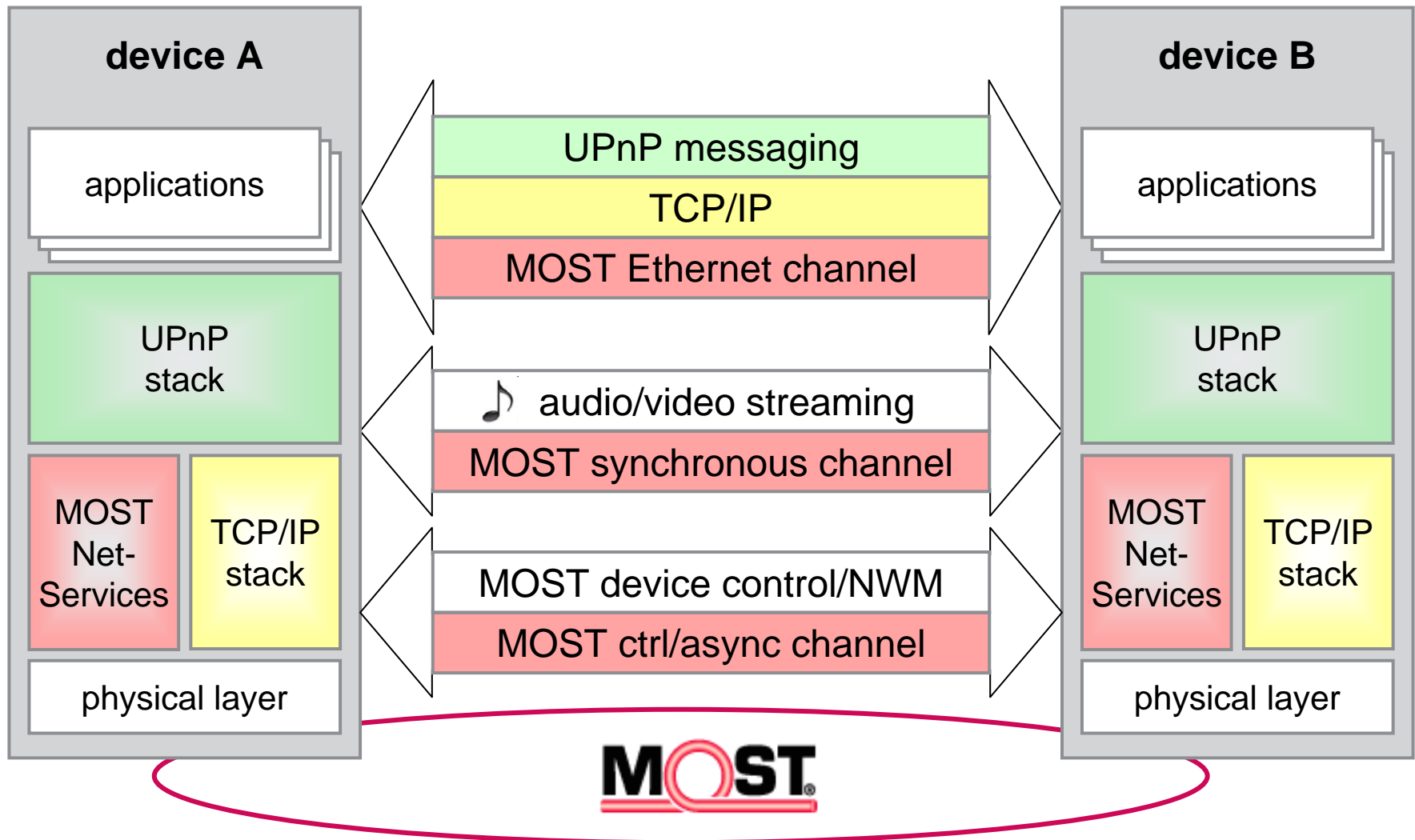

Example: Stream Handling

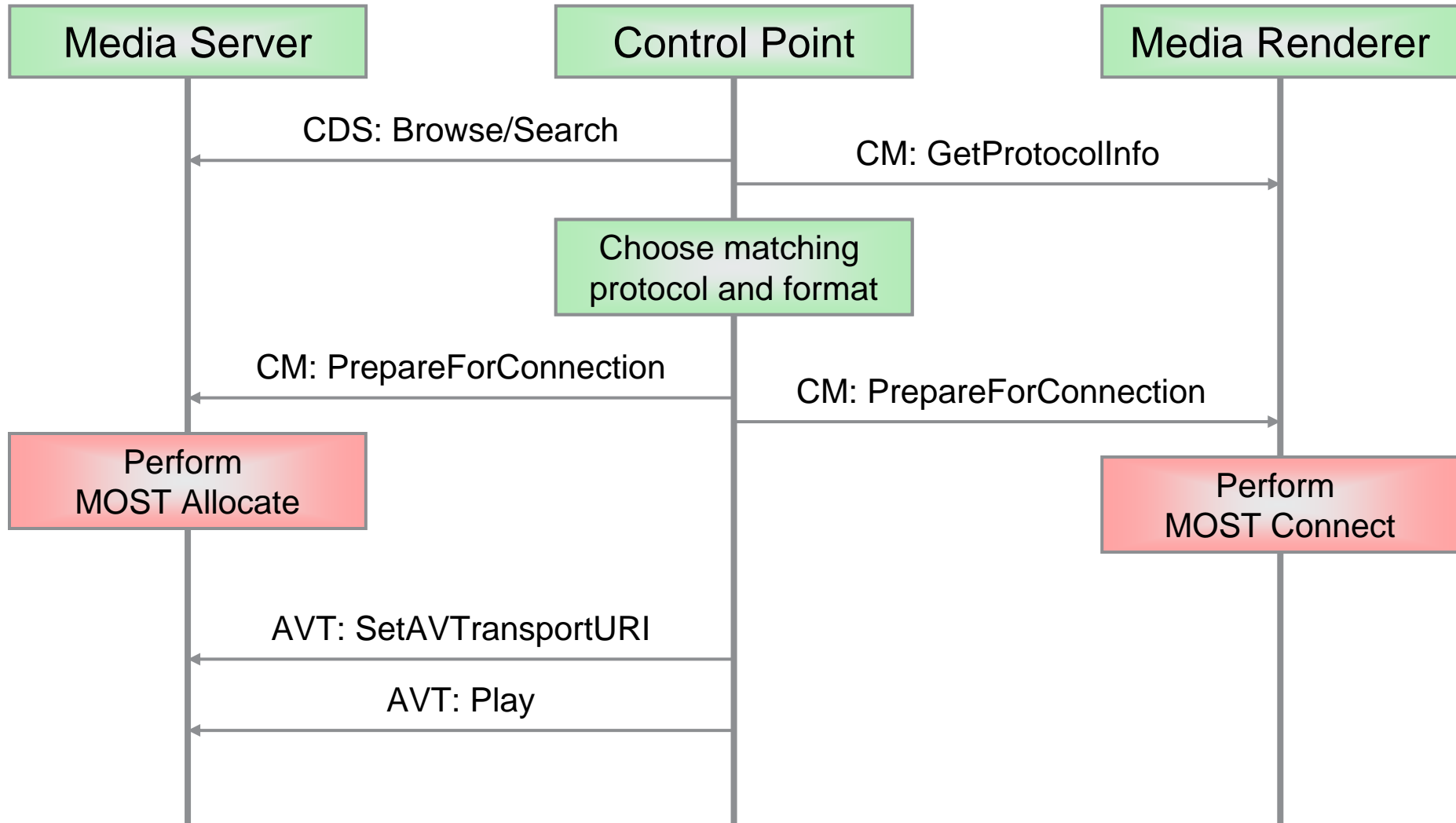

System Architecture

- master device for front seats – head unit
- controller devices for rear seats – sub unit(s)
- slave source devices: radio and TV tuners
- slave sink devices: audio amplifier

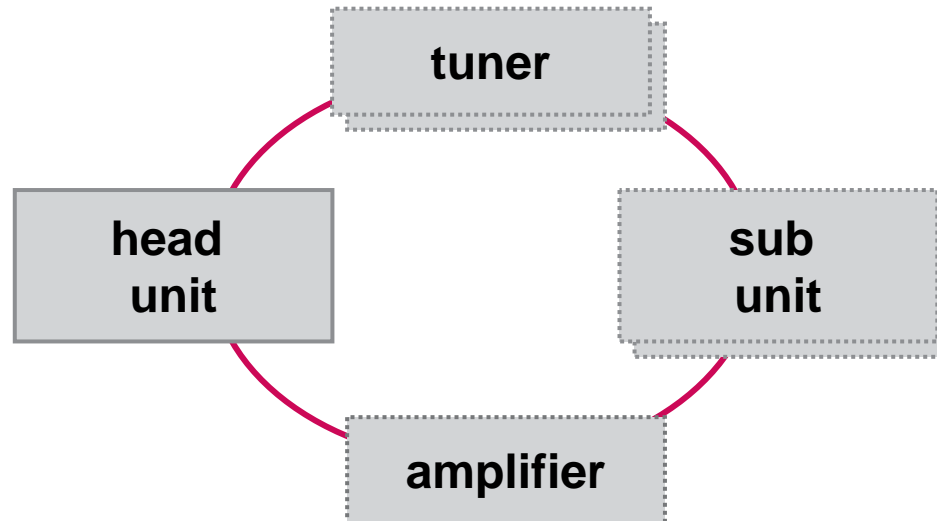

Stage One

- controller devices communicate via UPnP
- head unit is proxy for MOST amplifier

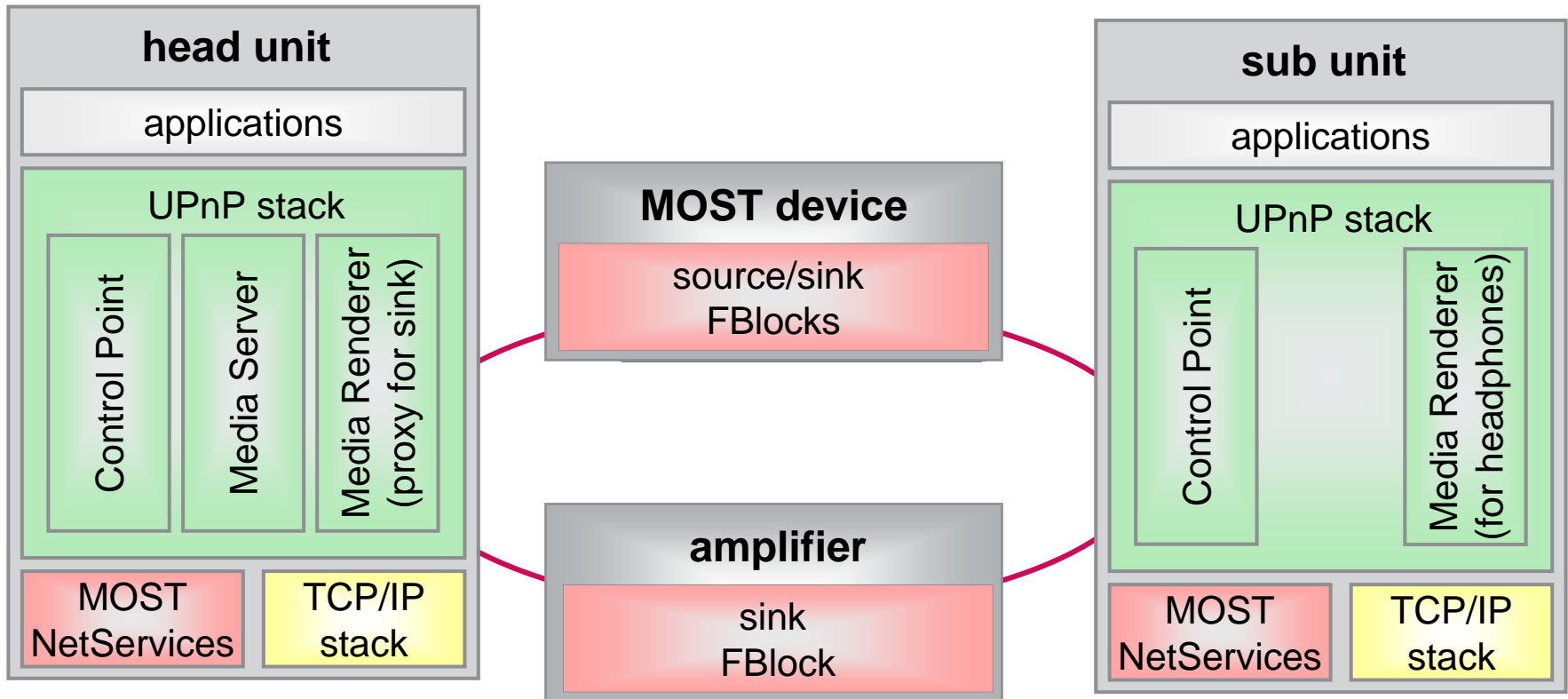

Stage Two

- UPnP services for FBlocks (proxy on head unit)
- UPnP consumer devices can use/provide services

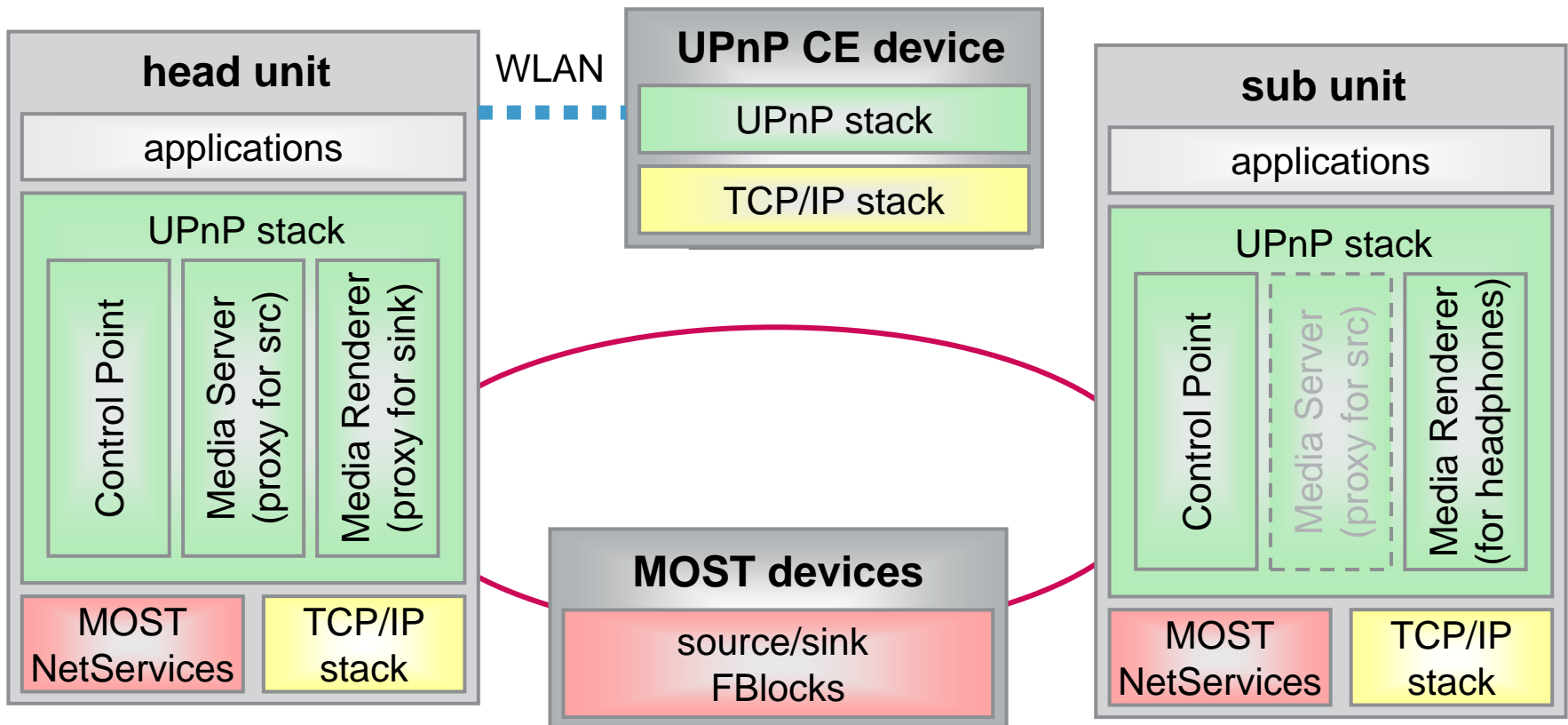

Stage Three

- all MOST devices support UPnP
- applications use UPnP for communication

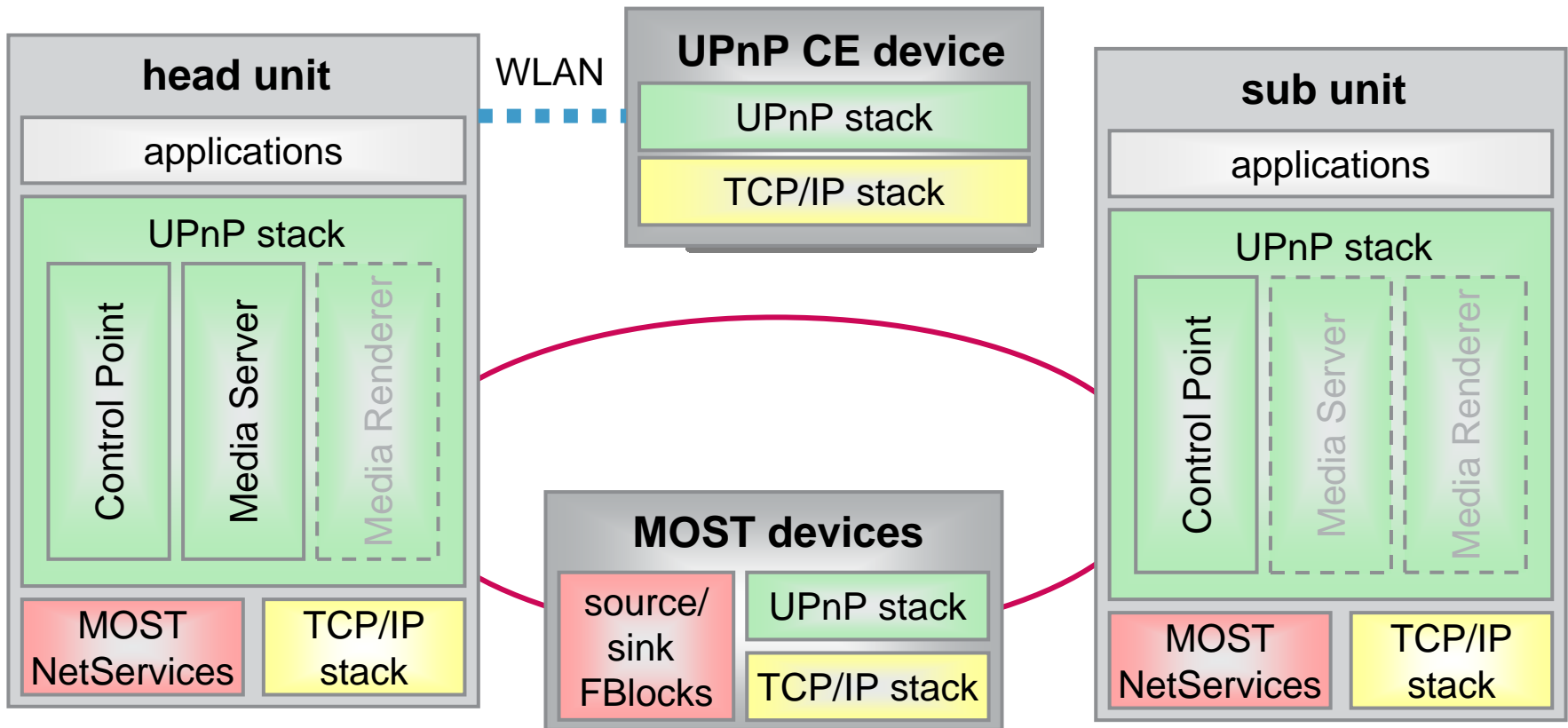

Conclusion

- utilize standard from consumer electronics
 - interface to CE devices
 - re-use SW and interfaces from CE world
- preserve strengths of MOST
 - reliable physical layer
 - easy transmission of multimedia data
- gradual introduction of UPnP

Contact

Thank you very much for your attention!

Questions?

Contact:

Dr. Alexander Leonhardi

HPC: X908

71059 Sindelfingen

Tel.: +49 160 86 32790

Email: alexander.leonhardi@daimler.com