

Usage of AUTOSAR Diagnostic Modules in a MOST Electronic Control Unit.

Concepts and Results from a first Prototype.

BMW Group



Content.

Introduction.

Porting the AUTOSAR Diagnostic Modules.

- Porting the DCM.
- Porting the DEM.
- Porting the CDC.

Porting Arbitrary Software Components.

Conclusion.

Introduction. Project Goal.

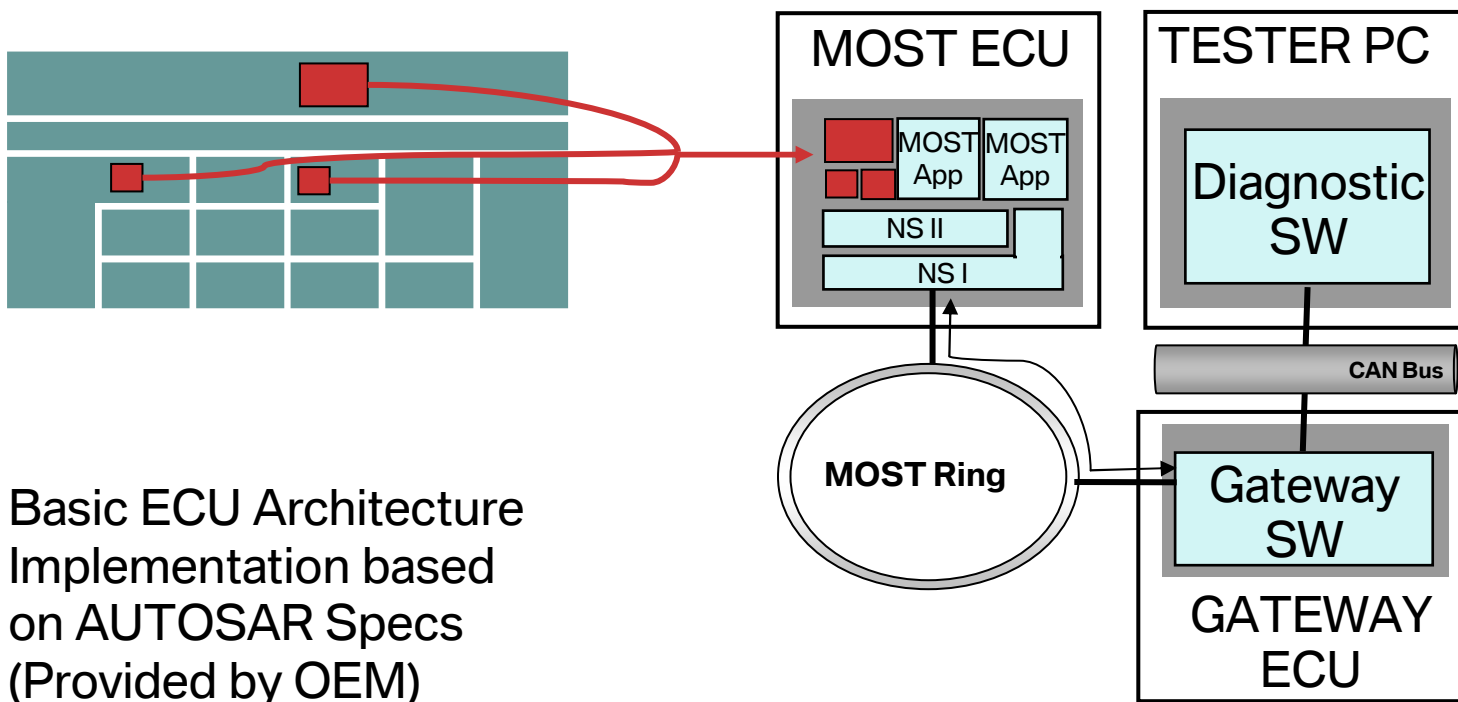

Introduction.

Motivation.

DON'T REPEAT YOURSELF!

- Frequent usage of software in different ECUs increases its quality.
- Especially for common system functionalities one implementation for all ECUs is desirable.
- As it reduces the effort of development.
- As it reduces the effort of testing.
- As it reduces the effort of integration.
- As it reduces the effort of updating.

Introduction.

AUTOSAR Architecture Overview.

Basic Software Modules (BSWMs).

- Provide common services required in most ECUs.

Runtime Environment (RTE).

- The RTE is a middleware which abstracts from the location of comm. partners.

Software Components (SW-Cs) .

- SW-Cs only communicate via the RTE with each other and BSWMs.

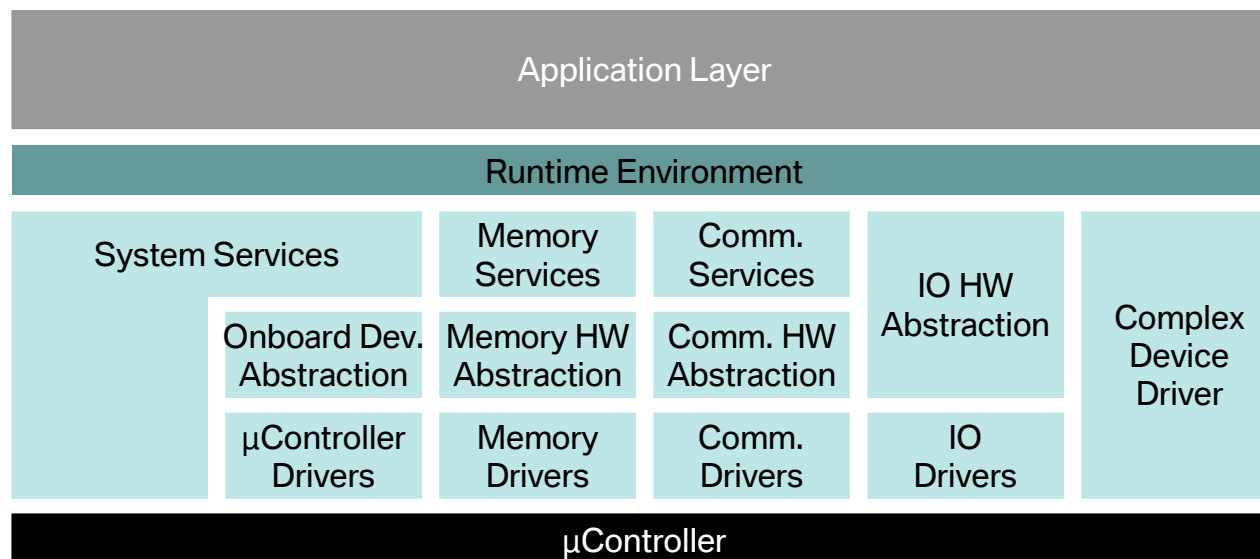

Introduction.

AUTOSAR Diagnostic Request Handling.

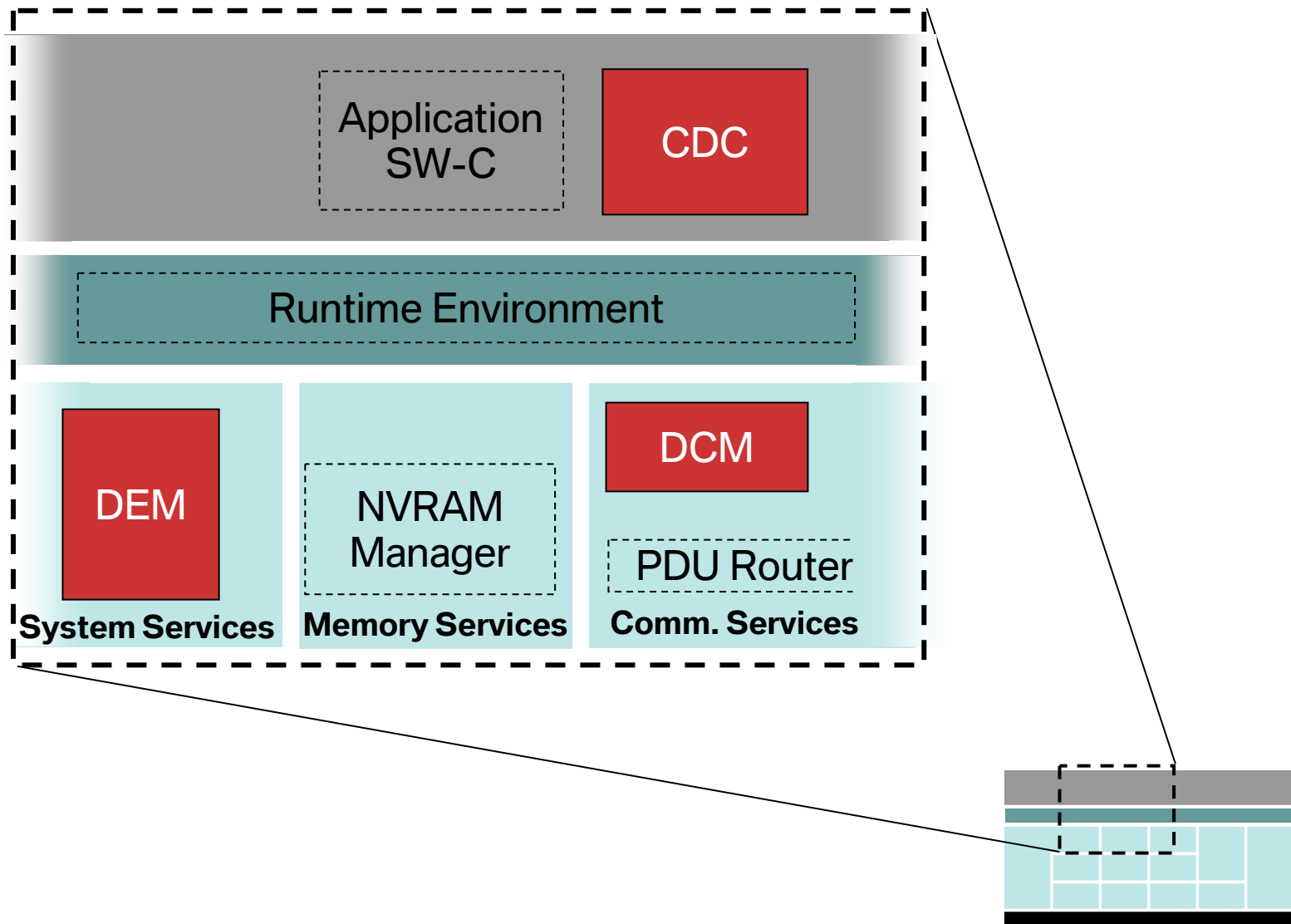

Introduction.

AUTOSAR Diagnostic Request Handling.

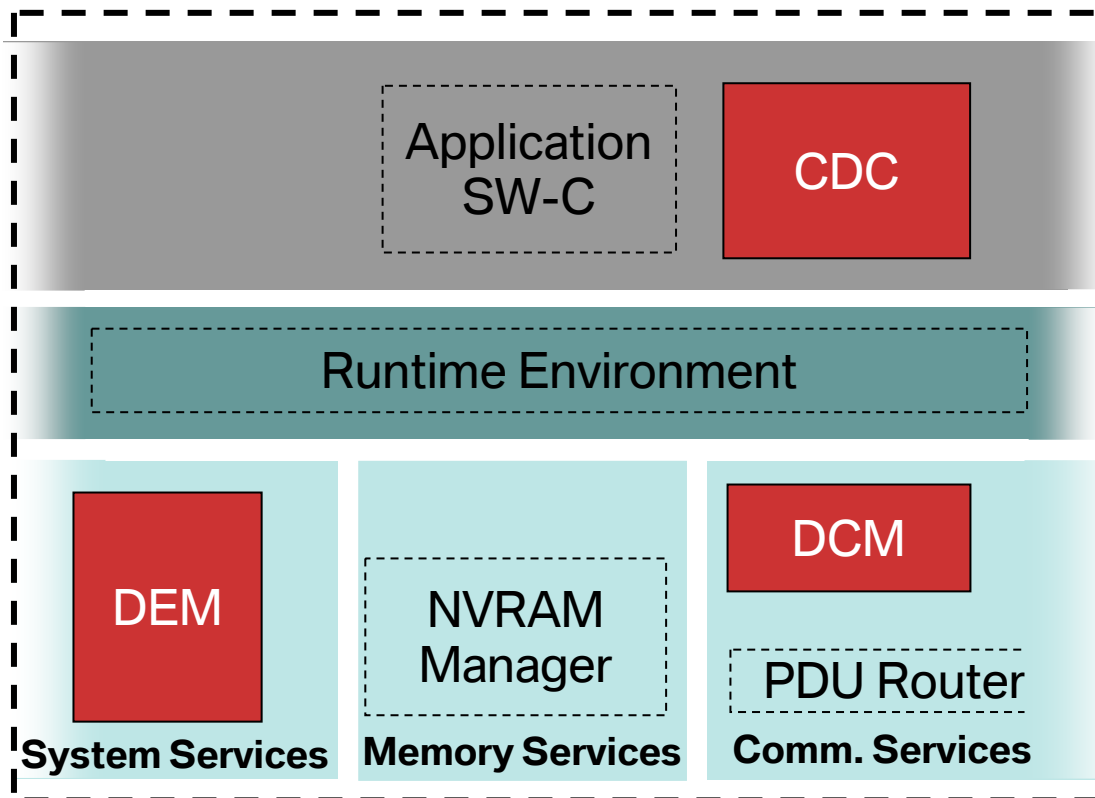

Central Diagnostic Software Component
Handles OEM specific diagnostic requests.

Diagnostic Event Manager
Handles error entries in a persistent manner.

Diagnostic Comm. Manager
Implements the KWP2000 & UDS protocols.

Introduction.

AUTOSAR Diagnostic Request Handling.

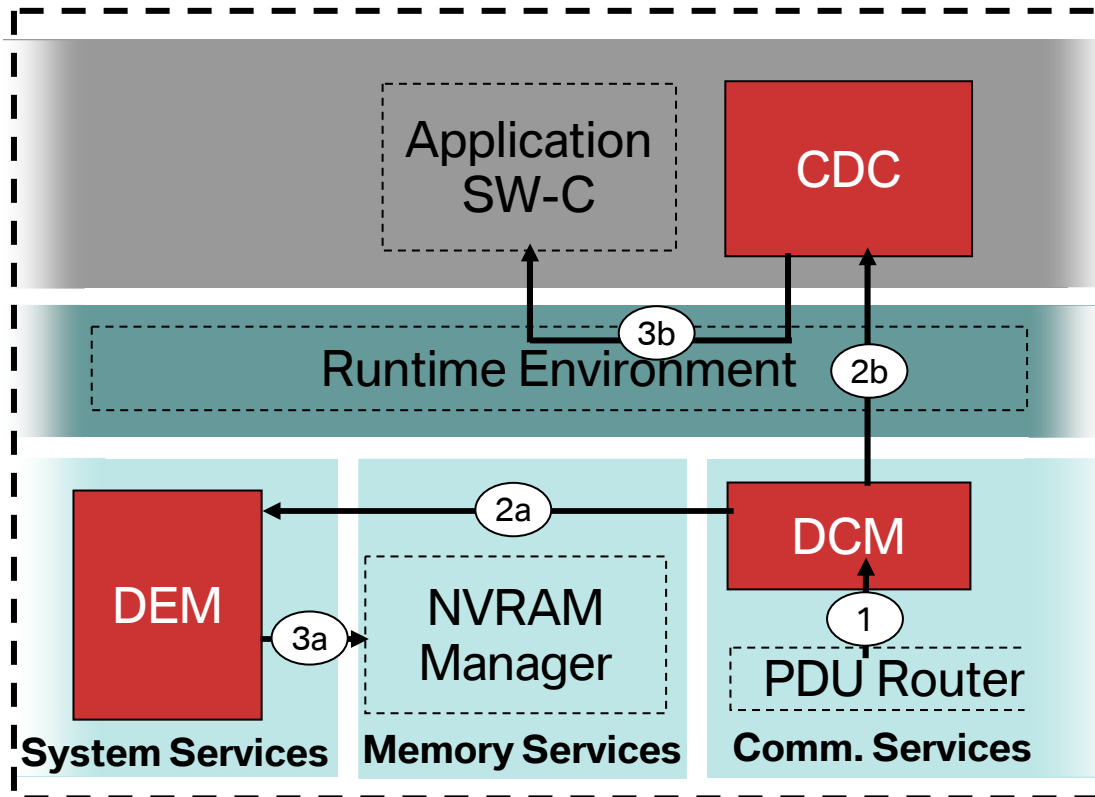

Central Diagnostic Software Component
Handles OEM specific diagnostic requests.

Diagnostic Event Manager
Handles error entries in a persistent manner.

Diagnostic Comm. Manager
Implements the KWP2000 & UDS protocols.

Content.

Introduction.

Porting the AUTOSAR Diagnostic Modules.

- Porting the DCM.
- Porting the DEM.
- Porting the CDC.

Porting Arbitrary Software Components.

Conclusion.

Porting the AUTOSAR Diagnostic Modules.

Porting AUTOSAR BSWMs & SW-Cs.

BSWMs & SWCs are deployed into and run in a non-AUTOSAR Environment (Linux/QNX & MOST).

BSWMs & SW-Cs Expectations

- BSWMs depend on the presence of other BSWMs.
- SWCs depend on the presence of the RTE.
- Not only interfaces are expected but also the specified behavior (triggering of functions).

Approach

- Emulation of the required BSWMs.
- Integration of the RTE.

Porting the AUTOSAR Diagnostic Modules. Overview.

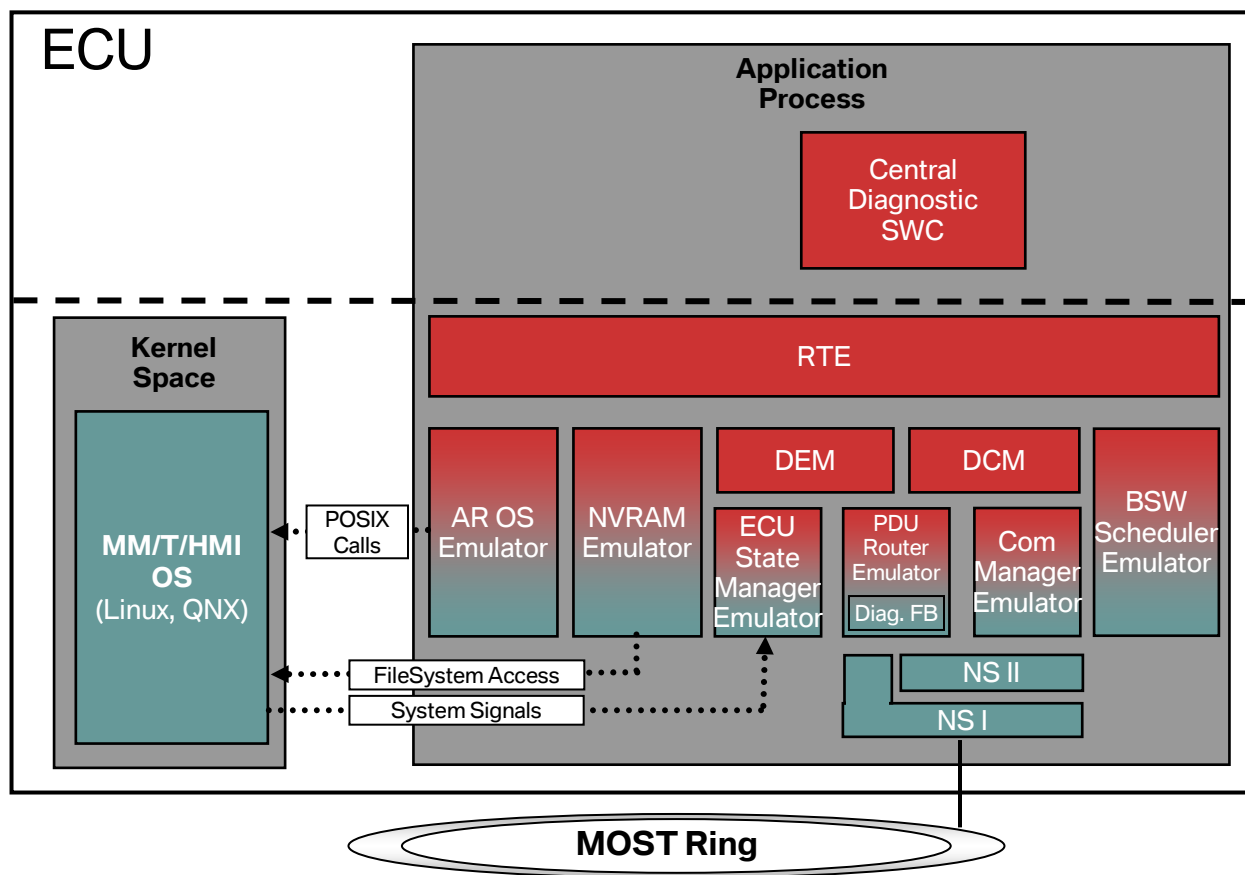

- AUTOSAR BSWM / SWC
- Non-AUTOSAR Software
- BSWM Emulator

Content.

Introduction.

Porting the AUTOSAR Diagnostic Modules.

- Porting the DCM.
- Porting the DEM.
- Porting the CDC.

Porting Arbitrary Software Components.

Conclusion.

Porting the DCM. Overview.

ComManager – Initializes the DCM and changes its mode (silent/listen/full).

PDU Router – DCM's access to comm. channels (send/receive messages).

BSW Scheduler – Triggers the DCM's main processing function.

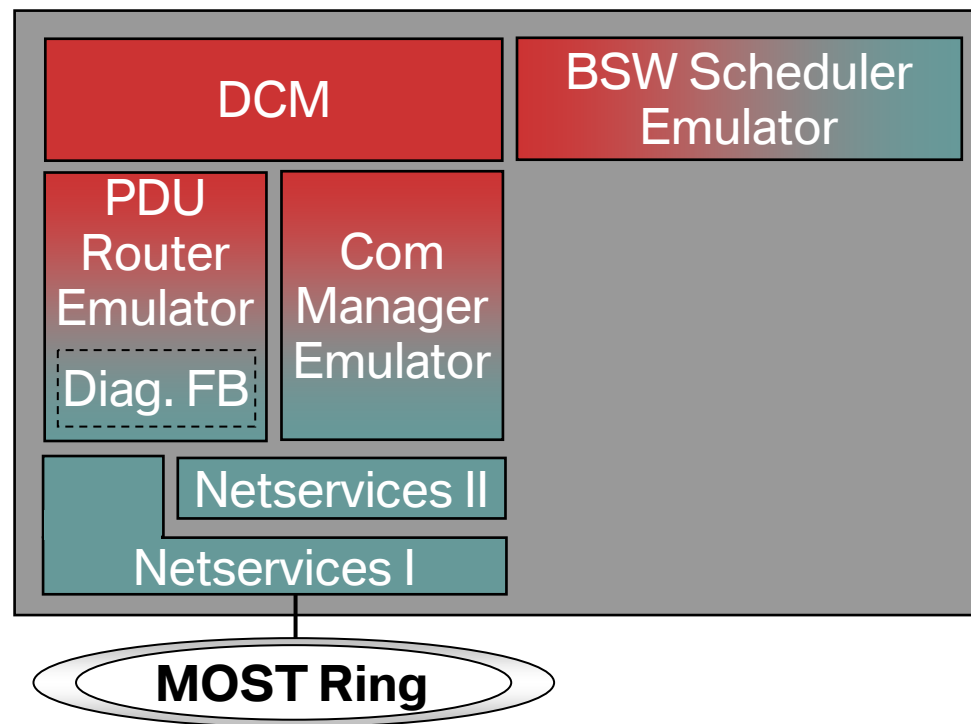

Porting the DCM. Initialization.

- The ComManager Emulator is attached to the `CommunicationSystemInit(byte ConfigStatusOk)` callback of the MOST Supervisor Layer II.
- The ComManager Emulator initializes and changes the DCM's communication mode based on the `ConfigStatusOk` parameter.

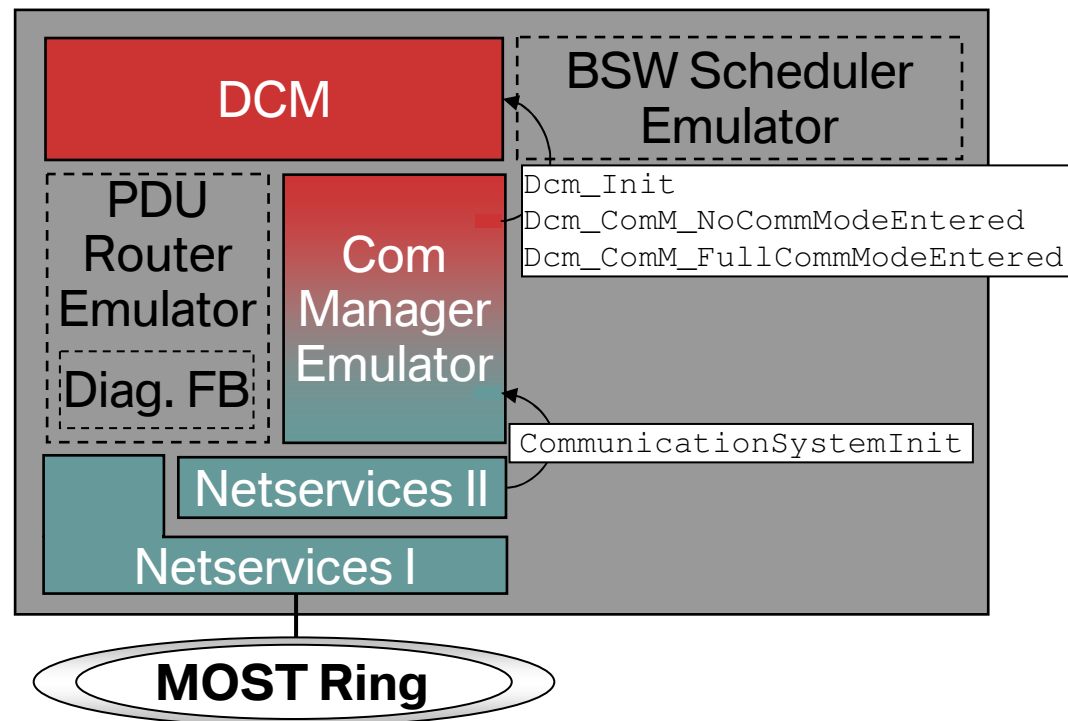

Porting the DCM. Communication Channel Access.

- The PDU Router Emulator provides a Function Block which is called by MOST's Command Interpreter on the reception of a diagnostic request.
- The PDU Router Emulator sends diagnostic responses by calling `MsgSend()` on MOST's Asynchronous Message Service.

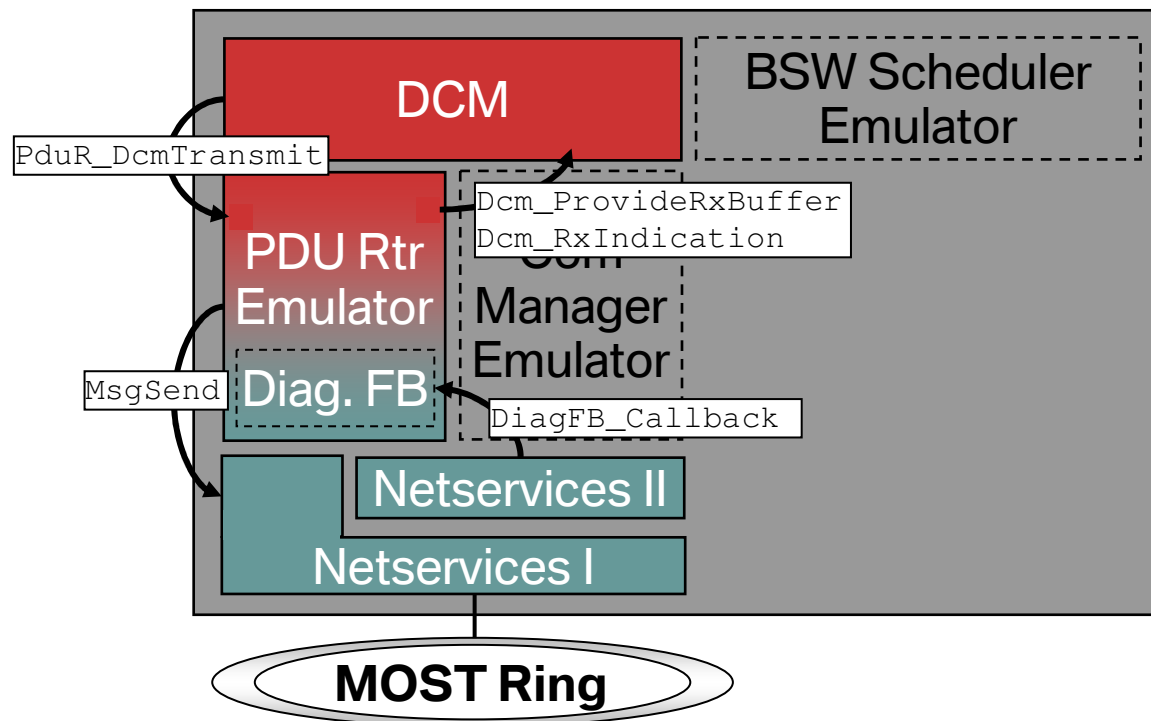

Porting the DCM. Scheduling.

- The DCM expects to be triggered periodically which is not desirable.
- The functions `ComM_DCM_ActiveDiagnostic()` and `ComM_DCM_InactiveDiagnostic()` can be used to only run the DCM on demand.

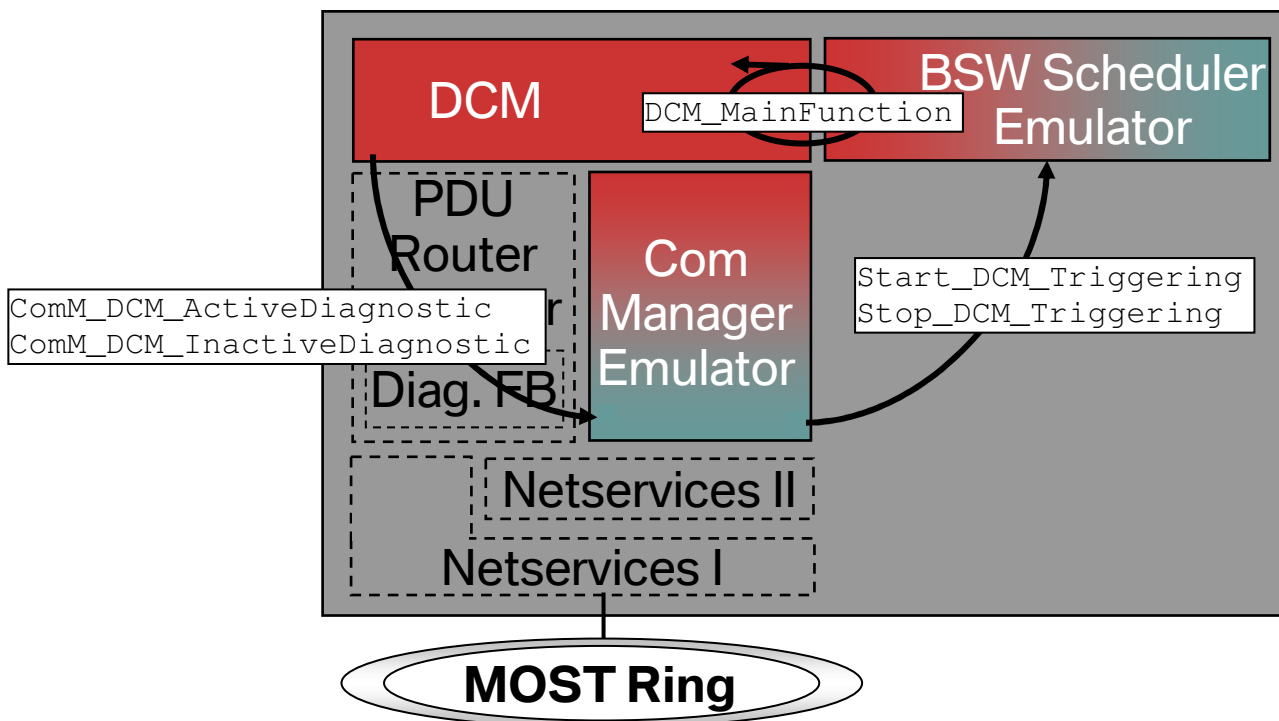

Content.

Introduction.

Porting the AUTOSAR Diagnostic Modules.

- Porting the DCM.
- Porting the DEM.
- Porting the CDC.

Porting Arbitrary Software Components.

Conclusion.

Porting the DEM. Overview.

ECU State Manager – Initializes the DEM.

NVRAM Manager – DCM's access to persistent storage.

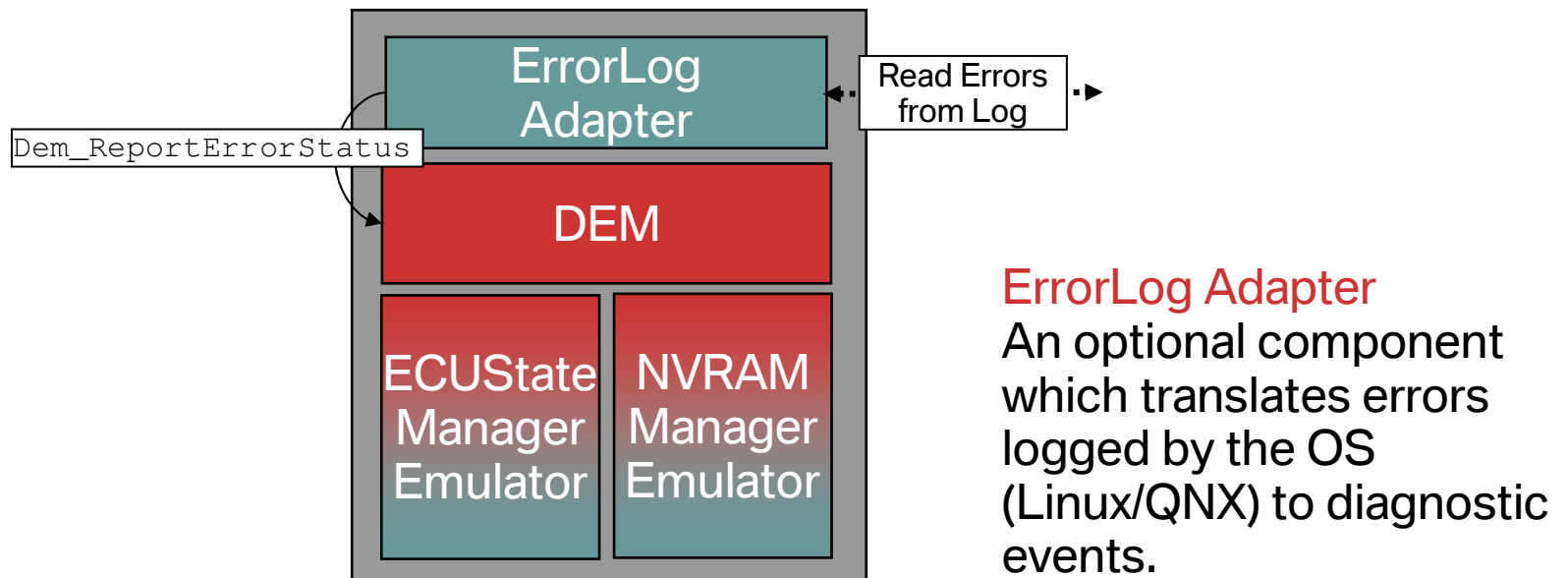

Porting the DEM. Initialization.

- The ECU State Manager Emulator is triggered in the `main()` function and hooked up with termination signals.
- The two phased initialization can be omitted.

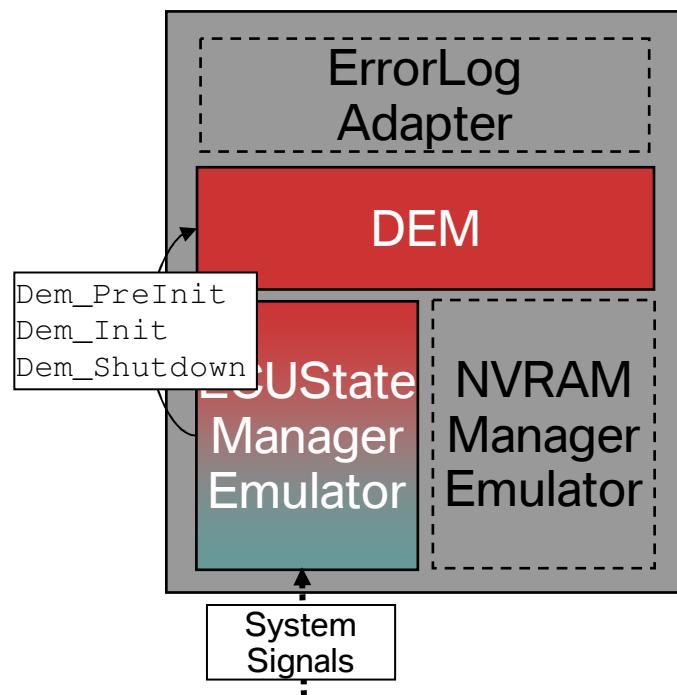

Porting the DEM.

Accessing Persistent Storage.

- The NVRAM Manager Emulator maps block ids to file names.
- A possible mapping would be to have one file per block id.

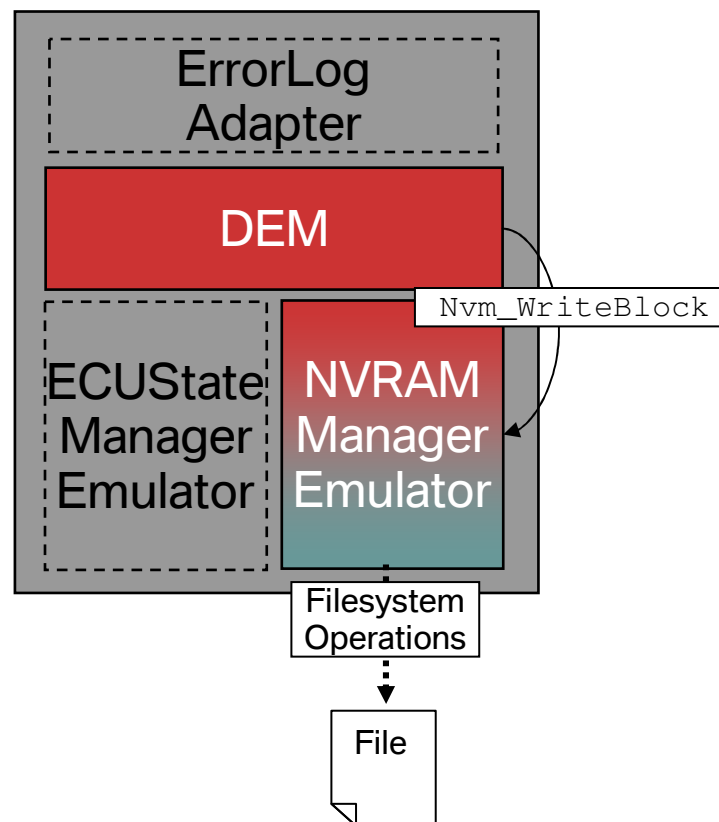

Content.

Introduction.

Porting the AUTOSAR Diagnostic Modules.

- Porting the DCM.
- Porting the DEM.
- **Porting the CDC.**

Porting Arbitrary Software Components.

Conclusion.

Porting the CDC. Overview.

- Software Components only communicate via the RTE.
- AUTOSAR has no MOST support, hence remote communication via the RTE is not possible – BUT not needed.
- Porting the CDC boils down to porting the RTE which implies the emulation of AUTOSAR OS services.

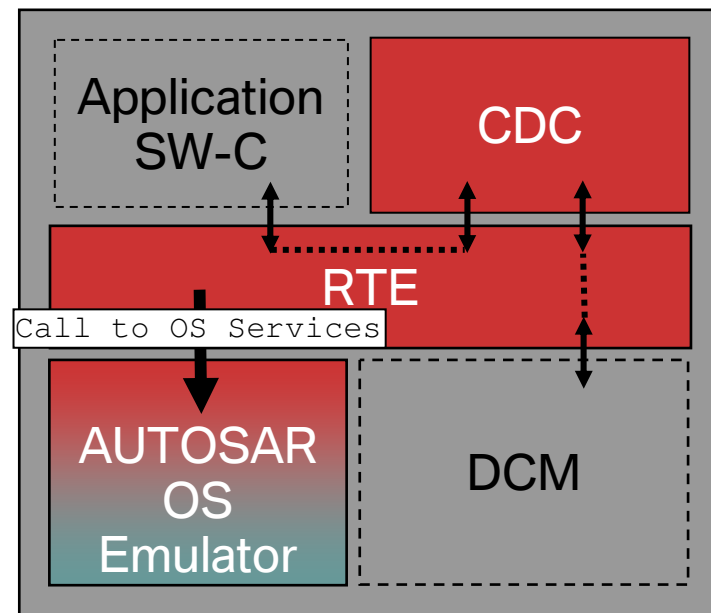

Porting the CDC.

Emulating AUTOSAR OS with POSIX.

`ActivateTask()` & `TerminateTask()`
Emulated by creating a POSIX Thread.

`SetRelAlarm()` & `CancelAlarm()`
Emulated by creating a POSIX Timer and setting the offset and period.

`SetEvent()`, `GetEvent()` & `ClearEvent()`
Emulated by setting bits in an `int` variable representing the occurred events.

`WaitEvent()`
Emulated by letting the Thread wait on a Condition which is signaled by the `SetEvent()` service.

Content.

Introduction.

Porting the AUTOSAR Diagnostic Modules.

- Porting the DCM.
- Porting the DEM.
- Porting the CDC.

Porting Arbitrary Software Components.

Conclusion.

Porting Arbitrary Software Components. The MOST Proxy Concept.

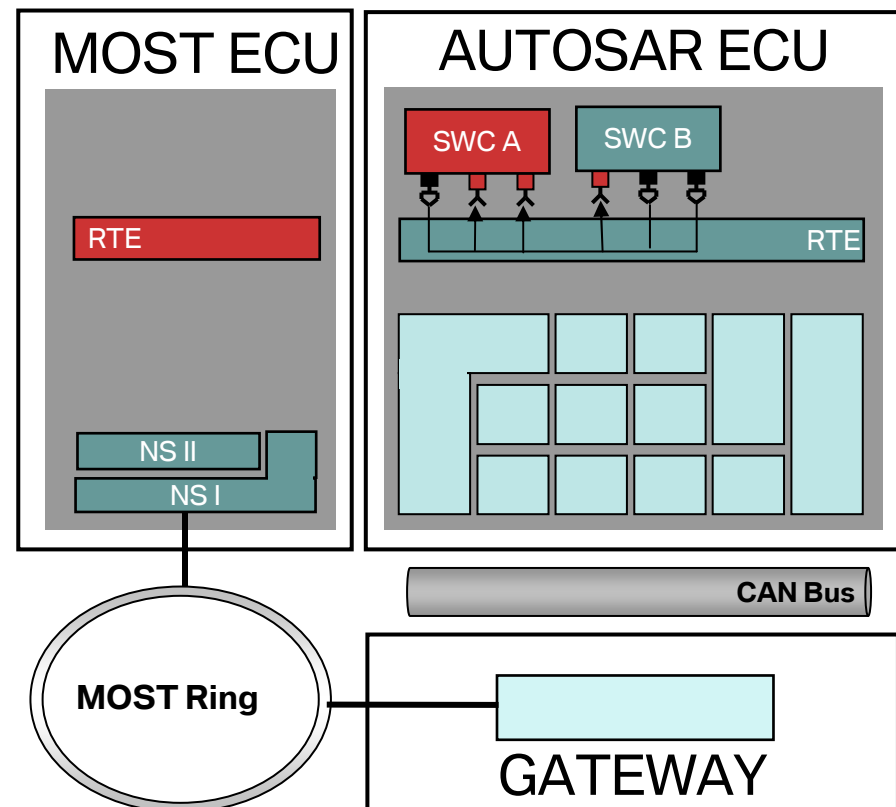

Porting Arbitrary Software Components. The MOST Proxy Concept.

- The RTE does not support access to the MOST Netservices.

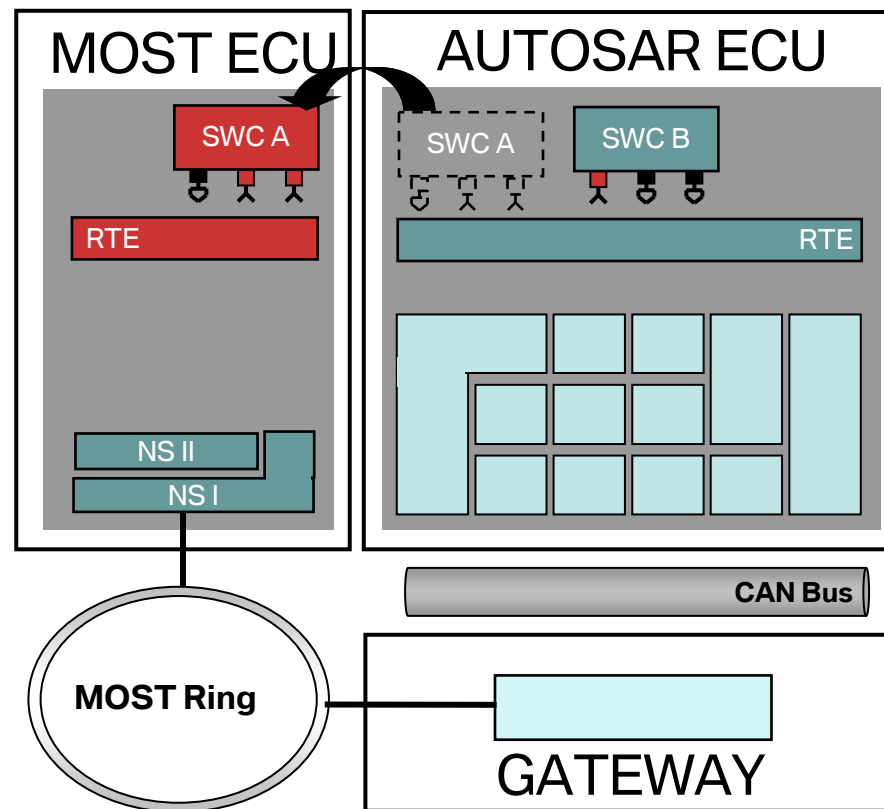

Porting Arbitrary Software Components. The MOST Proxy Concept.

- The RTE does not support access to the MOST Netservices.
- The MOST Proxy proxies the remote AUTOSAR SWC.
- The RTE only has to realize local communication.

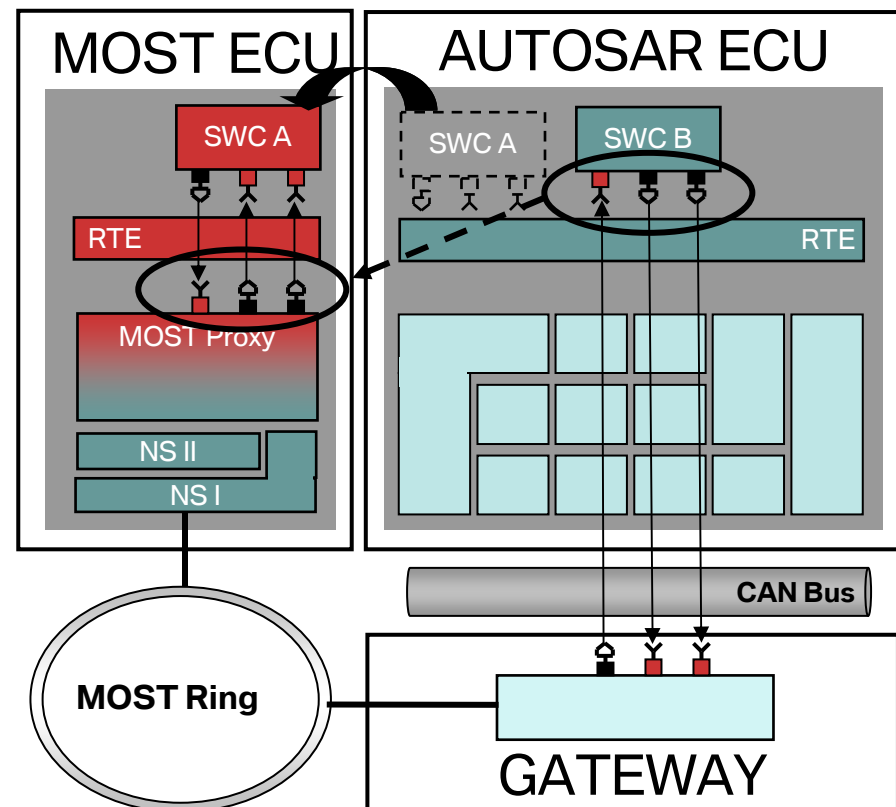

Porting Arbitrary Software Components. The MOST Proxy Concept.

- The RTE does not support access to the MOST Netservices.
- The MOST Proxy proxies the remote AUTOSAR SW-C.
- RTE only has to realize local communication.
- The MOST Proxy translates RTE-Calls to MOST FBlock-Calls.

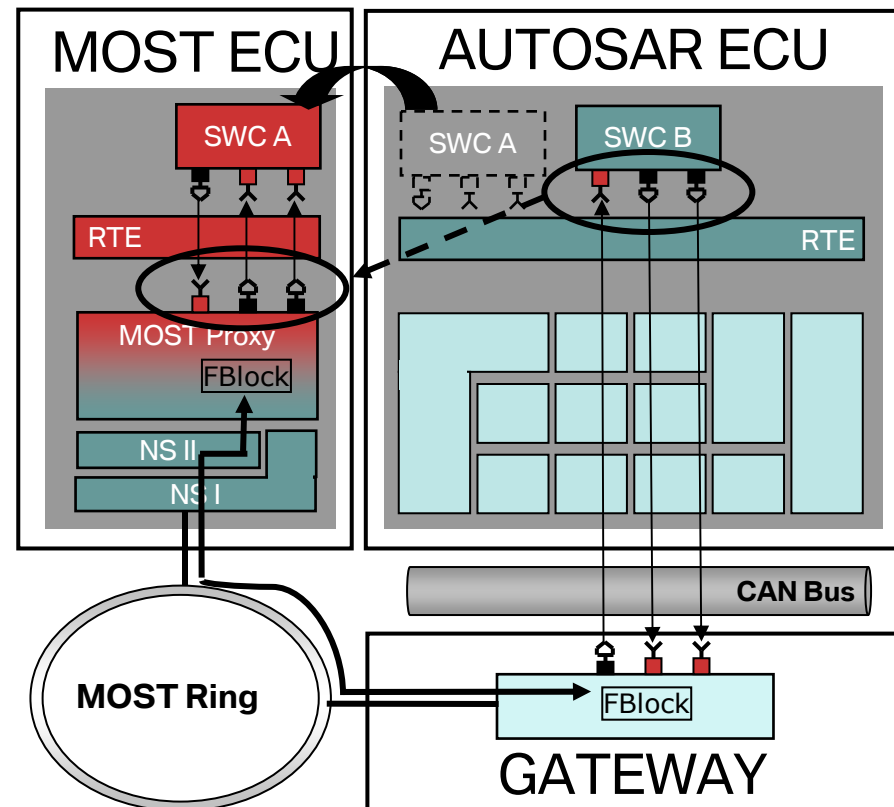

Content.

Introduction.

Porting the AUTOSAR Diagnostic Modules.

- Porting the DCM.
- Porting the DEM.
- Porting the CDC.

Porting Arbitrary Software Components.

Conclusion.

Conclusion.

MOST ECUs can benefit from AUTOSAR by reusing selected BSWMs & SWCs.

By providing a MOST Proxy MOST ECUs can host AUTOSAR SWCs.

A tighter coupling between AUTOSAR and MOST could increase the benefits of porting BSWMs (e.g. Netservices log errors via DEM).

Thank you for your attention.